



Airless Spray Technology

Owner's Manual

For professional use only

Do not use this equipment before reading this manual!

ProMark II

Line Striper



Model Number 759-2010

NOTE: This manual contains important warnings and instructions. Please read and retain for reference.

Table of Contents

Safety Precautions	2
Français	18
Español	20
General Description	4
Operation	4
Setup	4
Preparing to Paint.....	5
Painting	5
Pressure Relief Procedure	6
Cleanup	6
Cleaning the Spray Tip	7
Maintenance	7
General Repair and Service Notes.....	7
Maintaining the Engine	7
Replacing the Pump ON/OFF Switch.....	8
Replacing the Gears and/or Slider Assembly.....	8
Replacing the Electronic Pressure Control (EPC) Board.....	9
Replacing the Transducer.....	10
Servicing the Clutch Assembly	10
Servicing the Fluid Section	13
Replacing the Filter.....	14
Replacing the PRIME/SPRAY Valve.....	14
Replacing the Potentiometer	15
Accessories	15
Troubleshooting	16
Parts Listings	22
Main Assembly.....	22
Drive Assembly	23
Cart Assembly.....	24
Fluid Section Assembly	25
Electrical Schematic	25
Filter Assembly	26
PRIME/SPRAY Assembly	26
Wheel Assembly	26
Suction Hose Assembly	27
Return Hose Assembly	27
Gun Holder Assembly.....	27
Labels	27
Limited Warranty	28

Safety Precautions

This manual contains information that must be read and understood before using the equipment. When you come to an area that has one of the following symbols, pay particular attention and make certain to heed the safeguard.



This symbol indicates a potential hazard that may cause serious injury or loss of life. Important safety information will follow.



This symbol indicates a potential hazard to you or to the equipment. Important information that tells how to prevent damage to the equipment or how to avoid causes of minor injuries will follow.

NOTE: Notes give important information which should be given special attention.



HAZARD: Injection injury - A high pressure stream produced by this equipment can pierce the skin and underlying tissues, leading to serious injury and possible amputation. See a physician immediately.

DO NOT TREAT AN INJECTION INJURY AS A SIMPLE CUT! Injection can lead to amputation. See a physician immediately.

The maximum operating range of the gun is 3300 PSI / 22.8 MPa fluid pressure.

PREVENTION:

- NEVER aim the gun at any part of the body.
- NEVER allow any part of the body to touch the fluid stream. DO NOT allow body to touch a leak in the fluid hose.
- NEVER put your hand in front of the gun. Gloves will not provide protection against an injection injury.
- ALWAYS lock the gun trigger, shut the pump off, and release all pressure before servicing, cleaning the tip or guard, changing tip, or leaving unattended. Pressure will not be released by turning off the motor. The PRIME/SPRAY knob must be turned to PRIME to relieve the pressure. Refer to the PRESSURE RELIEF PROCEDURE described in the pump manual.
- ALWAYS keep the tip guard in place while spraying. The tip guard provides some protection but is mainly a warning device.
- ALWAYS remove the spray tip before flushing or cleaning the system.
- The paint hose can develop leaks from wear, kinking and abuse. A leak can inject material into the skin. Inspect the hose before each use.
- NEVER use a spray gun without a trigger lock and trigger guard in place and in good working order.
- All accessories must be rated at or above 3300 PSI / 22.8 MPa. This includes spray tips, guns, extensions, and hose.

NOTE TO PHYSICIAN:

Injection into the skin is a traumatic injury. It is important to treat the injury as soon as possible. DO NOT delay treatment to research toxicity. Toxicity is a concern with some coatings injected directly into the blood stream. Consultation with a plastic surgeon or reconstructive hand surgeon may be advisable.

HAZARD: EXPLOSION OR FIRE - Solvent and paint fumes can explode or ignite. Severe injury and/or property damage can occur.

PREVENTION:

- Provide extensive exhaust and fresh air introduction to keep the air within the spray area free from accumulation of flammable vapors.
- Avoid all ignition sources such as static electric sparks, open flames, pilot lights, and hot objects. Connecting or disconnecting power cords or working light switches can make sparks.
- Do not smoke in spray area.
- Fire extinguisher must be present and in good working order.
- Place paint pump in a well ventilated area. Flammable vapors are often heavier than air. Floor area must be extremely well ventilated. The paint pump contains arcing parts that emit spark and can ignite vapors.
- The equipment and objects in and around the spray area must be properly grounded to prevent static sparks.
- Use only conductive or grounded high pressure fluid hose. Gun must be grounded through hose connections.
- Power cord must be connected to a grounded circuit (electric models only).
- Always flush unit into a separate metal container, at low pump pressure, with spray tip removed. Hold gun firmly against side of container to ground container and prevent static sparks.
- Follow the material and solvent manufacturer's warnings and instructions.
- Use extreme caution when using materials with a flashpoint below 70° F (21° C). Flashpoint is the temperature that a fluid can produce enough vapors to ignite.
- Plastic can cause static sparks. Never hang plastic to enclose a spray area. Do not use plastic drop cloths when spraying flammable materials.
- Use lowest possible pressure to flush equipment.

GAS ENGINE (WHERE APPLICABLE)

Always place pump outside of structure in fresh air. Keep all solvents away from the engine exhaust. Never fill fuel tank with a running or hot engine. Hot surface can ignite spilled fuel. Always attach ground wire from pump unit to a grounded object, such as a metal water pipe. Refer to engine owner's manual for complete safety information.

HAZARD: EXPLOSION HAZARD DUE TO INCOMPATIBLE MATERIALS - Will cause severe injury or property damage.

PREVENTION:

- Do not use materials containing bleach or chlorine.
- Do not use halogenated hydrocarbon solvents such as mildewcide, methylene chloride and 1,1,1 - trichloroethane. They are not compatible with aluminum.
- Contact your coating supplier about the compatibility of material with aluminum.

HAZARD: HAZARDOUS VAPORS - Paints, solvents, insecticides, and other materials can be harmful if inhaled or come in contact with the body. Vapors can cause severe nausea, fainting, or poisoning.

PREVENTION:

- Use a respirator or mask if vapors can be inhaled. Read all instructions supplied with the mask to be sure it will provide the necessary protection.
- Wear protective eyewear.
- Wear protective clothing as required by coating manufacturer.

HAZARD: GENERAL - This product can cause severe injury or property damage.

PREVENTION:

- Read all instructions and safety precautions before operating equipment.
- Always disconnect the motor from the power supply before working on the equipment (electric models only).
- Follow all appropriate local, state, and national codes governing ventilation, fire prevention, and operation.
- The United States Government Safety Standards have been adopted under the Occupational Safety and Health Act (OSHA). These standards, particularly part 1910 of the General Standards and part 1926 of the Construction Standards should be consulted.
- Use only manufacturer authorized parts. User assumes all risks and liabilities when using parts that do not meet the minimum specifications and safety devices of the pump manufacturer.
- Before each use, check all hoses for cuts, leaks, abrasion or bulging of cover. Check for damage or movement of couplings. Immediately replace the hose if any of these conditions exist. Never repair a paint hose. Replace it with another grounded high-pressure hose.
- All hoses, swivels, guns, and accessories must be rated at or above 3300 PSI / 22.8 MPa.
- Do not spray outdoors on windy days.
- Wear clothing to keep paint off skin and hair.
- Always unplug cord from outlet before working on equipment.
- Do not use this equipment to spray water or acid.



Do not lift by cart handle when loading or unloading.

Gasoline Engine Safety



The engine exhaust from this unit contains chemicals known to the State of California to cause cancer, birth defects, or other reproductive harm.

1. Gas engines are designed to give safe and dependable service if operated according to instructions. Read and understand the engine Owner's Manual before operating the engine. Failure to do so could result in personal injury or equipment damage.
2. To prevent fire hazards and to provide adequate ventilation, keep the engine at least 1 meter (3 feet) away from buildings and other equipment during operation. Do not place flammable objects close to the engine.
3. Children and pets must be kept away from the area of operation due to a possibility of burns from hot engine components or injury from any equipment the engine may be used to operate.
4. Know how to stop the engine quickly, and understand the operation of all controls. Never permit anyone to operate the engine without proper instructions.
5. Gasoline is extremely flammable and is explosive under certain conditions.
6. Refuel in a well-ventilated area with the engine stopped. Do not smoke or allow flames or sparks in the refueling area or where gasoline is stored.
7. Do not overfill the fuel tank. After refueling, make sure the tank cap is closed properly and securely.
8. Be careful not to spill fuel when refueling. Fuel vapor or spilled fuel may ignite. If any fuel is spilled, make sure the area is dry before starting the engine.
9. Never run the engine in an enclosed or confined area. Exhaust contains poisonous carbon monoxide gas; exposure may cause loss of consciousness and may lead to death.
10. The muffler becomes very hot during operation and remains hot for a while after stopping the engine. Be careful not to touch the muffler while it is hot. To avoid severe burns or fire hazards, let the engine cool before transporting it or storing it indoors.
11. Never ship/transport unit with gasoline in the tank.

General Description

This airless line striper is a precision power tool used to spray many types of material for many types of applications including parking lots, curbs, and athletic fields. Read and follow this instruction manual carefully for proper operating instructions, maintenance, and safety information.

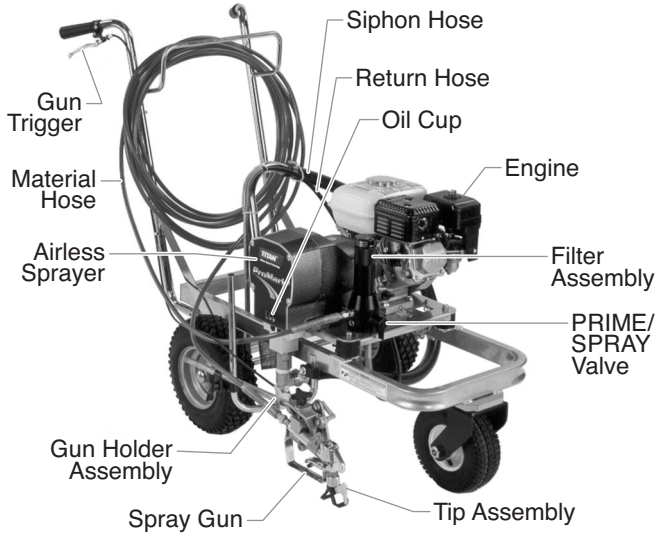

Operation



This equipment produces a fluid stream at extremely high pressure. Read and understand the warnings in the Safety Precautions section at the front of this manual before operating this equipment.

Setup

Perform the following procedure before starting the engine of a gas-powered line striper.

1. Ensure that the siphon hose and the return hose are attached and secure.
2. Position the spray gun.
 - a. Loosen the support bar clamp hex screw and rotate the gun support bar to the desired position. Tighten the hex screw securely.
 - b. Loosen the gun holder clamp knob and slide the spray gun to the desired vertical and horizontal (front-to-back) position. Tighten the knob securely.

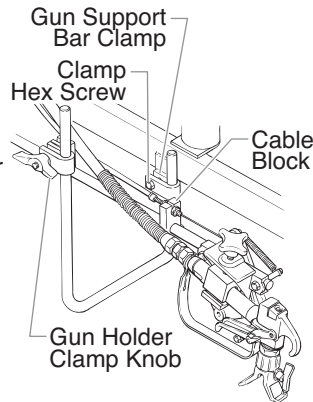

NOTE: The height of the spray gun affects the width of the spray pattern (i.e., the lower the gun, the smaller the line width). Tip size also affects line width.

3. Turn the pressure control knob fully counterclockwise to its lowest pressure setting.
4. Make sure the pump ON/OFF switch is in the OFF position.
5. Fill the fluid section oil cup with approximately one tablespoon of piston seal lubricant (Piston Lube).



Never operate unit for more than ten seconds without fluid. Operating this unit without fluid will cause unnecessary wear to the packings.

7. Check the engine oil level. The gasoline engine oil level is determined by the manufacturer. Refer to the engine manufacturer's service manual (supplied).

8. Close the fuel shut-off lever and fill the gas tank with gasoline. Use only high quality, unleaded gasoline.

NOTE: The gun support bar and the spray gun can be mounted on either side of the sprayer. To move the gun support bar:

- a. Remove the support bar clamp hex screw and nut.
- b. Move the gun support bar to the opposite side of the cart.
- c. Align the support bar clamp with the bracket on the cart.
- d. Thread the clamp hex screw through the gun support bar clamp and the bracket on the cart. Place the nut on the end of the clamp hex screw and tighten securely.

Adjusting the Trigger Tension

Use the following procedure to adjust the spring tension of the trigger lever on the gun holder assembly. The trigger lever pulls and releases the spray gun trigger when operated from the trigger on the cart. The proper tension ensures that the gun will shut off when the gun trigger is released. To ensure proper tension, there should be approximately a 1/32" to 1/16" gap between the trigger lever and the spray gun trigger.



Always keep the trigger lock on the spray gun in the locked position while making adjustments to the system.

1. Using a 5/32" hex wrench, loosen the set screw on the cable block.
2. Move the cable block in the appropriate direction to create a gap of 1/32" to 1/16" between the trigger lever and spray gun trigger.
 - a. Slide the cable block toward the gun to increase the gap between the trigger lever and spray gun trigger.
 - b. Slide the cable block away from the gun to decrease the gap between the trigger lever and spray gun trigger.

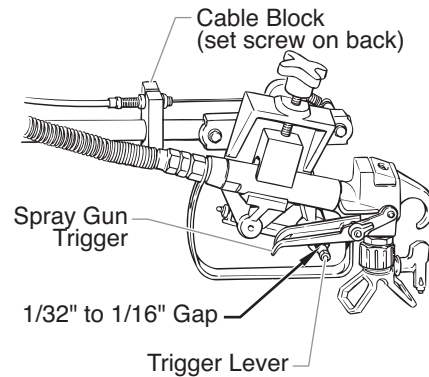

3. Tighten the set screw securely.

Preparing a New Sprayer

If this unit is new, it is shipped with test fluid in the fluid section to prevent corrosion during shipment and storage. This fluid must be thoroughly cleaned out of the system with mineral spirits before you begin spraying.



Always keep the trigger lock on the spray gun in the locked position while preparing the system.

1. Place the siphon tube into a container of mineral spirits that has a flash point of 60°C (140°F) or above.
2. Place the return hose into a metal waste container.
3. Turn the pressure control knob fully counterclockwise to its lowest pressure setting.
4. Move the PRIME/SPRAY valve to the PRIME position.
5. Move the engine ON/OFF switch to the ON position.

6. Start the engine:
 - a. Open the fuel valve lever.
 - b. Move the throttle lever away from the gas tank.
 - c. Close the engine choke lever.

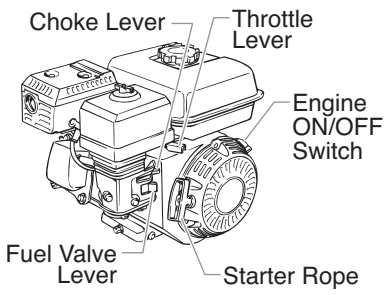

- d. Holding the frame with one hand, pull the starter rope rapidly and firmly. Continue to hold the rope as you let it return. Pull and return the rope until the engine starts.
7. Turn on the sprayer by moving the pump ON/OFF switch to the ON position.
8. Slowly turn the pressure control knob clockwise to increase the pressure until fluid starts to come out of the return hose. Use only enough pressure to keep the fluid coming out.
9. Allow the sprayer to run for 15–30 seconds to flush the test fluid out through the return hose and into the waste container.
10. Turn the pressure control knob fully counterclockwise to its lowest setting.
11. Turn off the sprayer by moving the pump ON/OFF switch to the OFF position.

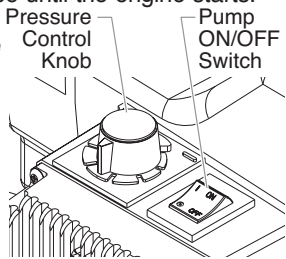

Preparing to Paint

Before painting, it is important to make sure that the fluid in the system is compatible with the paint that is going to be used.

NOTE: Incompatible fluids and paint may cause the valves to become stuck closed, which would require disassembly and cleaning of the sprayer's fluid section.

CAUTION

Always keep the trigger lock on the spray gun in the locked position while preparing the system.

1. Place the siphon tube into a container of the appropriate solvent for the material being sprayed (refer to recommendations of the material manufacturer). An example of the appropriate solvent is water for latex paint.
2. Place the return hose into a metal waste container.
3. Turn the pressure control knob fully counterclockwise to its lowest pressure setting.
4. Move the PRIME/SPRAY valve to the PRIME position.
5. Move the engine ON/OFF switch to the ON position.
6. Start the engine:
 - a. Open the fuel valve lever.
 - b. Move the throttle lever away from the gas tank.
 - c. Close the engine choke lever.
 - d. Holding the frame with one hand, pull the starter rope rapidly and firmly. Continue to hold the rope as you let it return. Pull and return the rope until the engine starts.
7. Turn on the sprayer by moving the pump ON/OFF switch to the ON position.
8. Slowly turn the pressure control knob clockwise to increase the pressure until fluid starts to come out of the return hose. Use only enough pressure to keep the fluid coming out.
9. Allow the sprayer to run for 15–30 seconds to flush the old solvent out through the return hose and into the metal waste container.
10. Turn the pressure control knob fully counterclockwise to its lowest setting.
11. Turn off the sprayer by moving the pump ON/OFF switch to the OFF position.

NOTE: Make sure that the spray gun does not have a tip or tip guard installed.

12. Move the PRIME/SPRAY valve to the SPRAY position.
13. Turn on the sprayer.
14. Turn the pressure control knob slowly clockwise to increase pressure.
15. Unlock the gun by turning the gun trigger lock to the unlocked position.

WARNING

Ground the gun by holding it against the edge of the metal container while flushing. Failure to do so may lead to a static electric discharge, which may cause a fire.

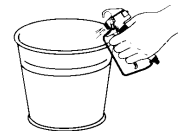

16. Trigger the gun into the metal waste container until the old solvent is gone and fresh solvent is coming out of the gun.
17. Lock the gun by turning the gun trigger lock to the locked position.
18. Set down the gun and increase the pressure by turning the pressure control knob slowly clockwise to its highest setting.
19. Check the entire system for leaks. If leaks occur, turn the sprayer off and follow the "Pressure Relief Procedure" in this manual before tightening any fittings or hoses.
20. Follow the "Pressure Relief Procedure" in this manual before changing from solvent to paint.

WARNING

Be sure to follow the pressure relief procedure when shutting the unit down for any purpose, including servicing or adjusting any part of the spray system, changing or cleaning spray tips, or preparing for cleanup.

Painting

1. Place the siphon tube into a container of paint.
2. Place the return hose into a metal waste container.
3. Turn the pressure control knob fully counterclockwise to its lowest pressure setting.
4. Move the PRIME/SPRAY valve to the PRIME position.
5. Move the engine ON/OFF switch to the ON position.

6. Start the engine:

- a. Open the fuel valve lever.
- b. Move the throttle lever away from the gas tank.
- c. Close the engine choke lever.

- d. Holding the frame with one hand, pull the starter rope rapidly and firmly. Continue to hold the rope as you let it return. Pull and return the rope until the engine starts.

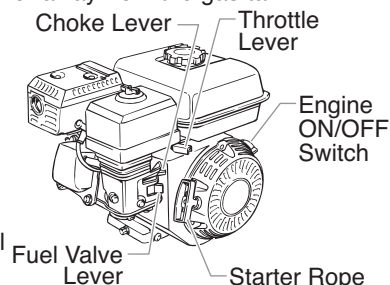

7. Turn on the sprayer by moving the pump ON/OFF switch to the ON position.

8. Slowly turn the pressure control knob clockwise to increase the pressure until fluid starts to come out of the return hose. Use only enough pressure to keep the fluid coming out.
9. Allow the sprayer to run until paint is coming through the return hose into the metal waste container.

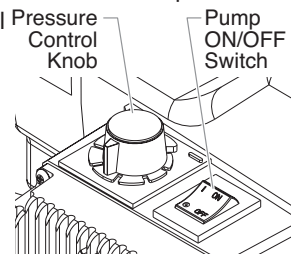

10. Turn the pressure control knob fully counterclockwise to its lowest setting.
11. Turn off the sprayer by moving the pump ON/OFF switch to the OFF position.

- Remove the return hose from the waste container and place it in its operating position above the container of paint.
- Move the PRIME/SPRAY valve to the SPRAY position.
- Turn on the sprayer.
- Turn the pressure control knob slowly clockwise to increase pressure.
- Unlock the gun by turning the gun trigger lock to the unlocked position.

⚠ WARNING

Ground the gun by holding it against the edge of the metal container while flushing. Failure to do so may lead to a static electric discharge, which may cause a fire.



- Trigger the gun into the metal waste container until all air and solvent is flushed from the spray hose and paint is flowing freely from the gun.
- Lock the gun by turning the gun trigger lock to the locked position.
- Turn the pressure control knob fully counterclockwise to its lowest setting.
- Turn off the sprayer.
- Attach tip guard and tip to the gun as instructed by the tip guard or tip manuals.

⚠ WARNING

POSSIBLE INJECTION HAZARD. Do not spray without the tip guard in place. Never trigger the gun unless the tip is in either the spray or the unclog position. Always engage the gun trigger lock before removing, replacing or cleaning tip.

- Turn on the sprayer.
- Increase the pressure by turning the pressure control knob slowly clockwise. Test the spray pattern and line position on a long piece of roofing felt or cardboard.
 - Adjust the pressure control knob until the spray from the gun is completely atomized. Try to keep the pressure control knob at the lowest setting that maintains good atomization.

NOTE: Turning the pressure up higher than needed to atomize the paint will cause premature tip wear and additional overspray.

- Check for proper line width and position. If adjustment to the position of the spray gun is required, refer to the "Setup" procedure earlier in this section.
- Make sure that the spray gun completely shuts off when the gun trigger is released. If adjustment to the trigger tension is required, refer to the "Adjusting the Trigger Tension" procedure earlier in this section.

Pressure Relief Procedure

⚠ WARNING

Be sure to follow the pressure relief procedure when shutting the unit down for any purpose, including servicing or adjusting any part of the spray system, changing or cleaning spray tips, or preparing for cleanup.

- Lock the gun by turning the gun trigger lock to the locked position.
- Turn off the sprayer by moving the pump ON/OFF switch to the OFF position.
- Turn off the engine by moving the engine ON/OFF switch to the OFF position.
- Turn the pressure control knob counterclockwise to its lowest setting.
- Unlock the gun by turning the gun trigger lock to the unlocked position.

- Hold the metal part of the gun firmly to the side of a metal container to ground the gun and avoid a build up of static electricity.
- Trigger the gun to remove any pressure that may still be in the hose.
- Lock the gun by turning the gun trigger lock to the locked position.
- Move the PRIME/SPRAY valve to the PRIME position.

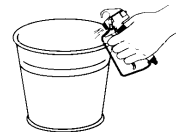

Cleanup

⚠ WARNING

Special cleanup instructions for use with flammable solvents:

- Always flush spray gun preferably outside and at least one hose length from spray pump.
- If collecting flushed solvents in a one gallon metal container, place it into an empty five gallon container, then flush solvents.
- Area must be free of flammable vapors.
- Follow all cleanup instructions.

⚠ CAUTION

The sprayer, hose, and gun should be cleaned thoroughly after daily use. Failure to do so permits material to build up, seriously affecting the performance of the unit.

⚠ WARNING

Always spray at minimum pressure with the gun nozzle tip removed when using mineral spirits or any other solvent to clean the sprayer, hose, or gun. Static electricity buildup may result in a fire or explosion in the presence of flammable vapors.

- Follow the "Pressure Relief Procedure" found in the Operation section of this manual.
- Remove the gun tip and tip guard and clean with a brush using the appropriate solvent.
- Place the siphon tube into a container of the appropriate solvent (refer to recommendations of the material manufacturer). An example of the appropriate solvent is water for latex paint.
- Place the return hose into a metal waste container.
- Move the PRIME/SPRAY valve to its PRIME position.
- Move the engine ON/OFF switch to the ON position and start the engine.
- Turn on the sprayer by moving the pump ON/OFF switch to the ON position.
- Slowly turn the pressure control knob clockwise to increase the pressure until fluid starts to come out of the return hose.
- Allow the solvent to circulate through the sprayer and flush the paint out of the return hose into the metal waste container.
- Turn the pressure control knob fully counterclockwise to its lowest setting.
- Turn off the sprayer by moving the ON/OFF switch to the OFF position.
- Move the PRIME/SPRAY valve to its SPRAY position.
- Turn on the sprayer.
- Turn the pressure control knob slowly clockwise to increase pressure.

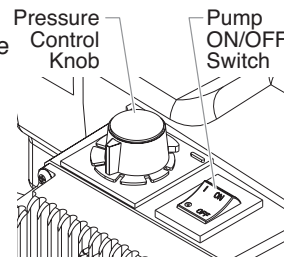

⚠ WARNING

Ground the gun by holding it against the edge of the metal container while flushing. Failure to do so may lead to a static electric discharge, which may cause a fire.



15. Trigger the gun into the metal waste container until the paint is flushed out of the hose and solvent is coming out of the gun.
16. Continue to trigger the spray gun into the waste container until the solvent coming out of the gun is clean.

NOTE: For long-term or cold weather storage, pump mineral sprits through the entire system.

17. Follow the "Pressure Relief Procedure" found in the Operation section of this manual.
18. Store the sprayer in a clean, dry area.

⚠ CAUTION

Do not store the sprayer under pressure.

Cleaning the Spray Tip

1. Flush the gun with solvent immediately after the work is completed.
2. Oil the sliding pins to prevent them from seizing up.

Should the spray tip become clogged, reverse the spray tip with the lever and pull the trigger. Once the obstruction comes out of the spray tip, release the trigger, reverse the spray tip back to the spray pattern setting, and resume spraying.



⚠ WARNING

Do not attempt to clean the tip with your finger.

Do not use a needle or other sharp pointed instrument to clean the tip. The hard tungsten carbide is brittle and can be chipped.

Maintenance

⚠ WARNING

Before proceeding, follow the Pressure Relief Procedure outlined previously in this manual. Additionally, follow all other warnings to reduce the risk of an injection injury, injury from moving parts, or electric shock.

NOTE: All Honda engine work should be performed by a Honda authorized service center.

General Repair and Service Notes

The following tools are needed when repairing this sprayer:

Phillips screwdriver	3/8" hex wrench
needle-nose pliers	5/16" hex wrench
adjustable wrench	1/4" hex wrench
rubber mallet	3/16" hex wrench
flat-blade screwdriver	1/8" hex wrench
1/2" open-end wrench	7/8" open-end wrench

1. Before repairing any part of the sprayer, read the instructions carefully, including all warnings.

⚠ CAUTION

Never pull on a wire to disconnect it. Pulling on a wire could loosen the connector from the wire.

2. Test your repair before regular operation of the sprayer to be sure that the problem is corrected. If the sprayer does not operate properly, review the repair procedure to determine if everything was done correctly. Refer to the Troubleshooting section to help identify other possible problems.
3. Make certain that the service area is well ventilated in case solvents are used during cleaning. Always wear protective eyewear while servicing. Additional protective equipment may be required depending on the type of cleaning solvent. Always contact the supplier of solvents for recommendations.
4. If you have any further questions concerning your TITAN Airless Sprayer, call TITAN:

Customer Service (U.S.) 1-800-526-5362

Fax 1-800-528-4826

Maintaining the Engine

⚠ WARNING

When transporting a sprayer with a gas engine, make sure the fuel is shut off.

NOTE: For detailed engine specifications and maintenance, refer to the separate engine manual supplied with this sprayer.

Important Facts Concerning this Sprayer

This gas-powered sprayer contains a clutch that engages when the sprayer is pumping. The sprayer's pressure control system engages and disengages the clutch to control pressure. To prevent unnecessary wear to the clutch, it is advisable to adjust the engine speed and pressure setting to limit the amount of times the clutch engages and disengages. To reduce clutch wear, refer to the following examples.

Example:

Operating one gun with a .019 tip — reduce the engine speed by adjusting the throttle to a low or medium setting and increase pressure only until the heavy ends of the spray pattern have been eliminated.

Example:

Operating one gun with .023 tip — increase engine speed to a high setting and increase pressure until the heavy ends of the spray pattern have been eliminated.

Example:

Spraying light-bodied materials at low pressure — to reduce surging at the gun and to decrease clutch wear, reduce the engine speed to idle and reduce pressure until the desired spray pattern is achieved.

Routine Engine Maintenance

Daily

- Check and fill the gas tank.
- After the first 20 hours of operation, drain the oil and refill with clean oil. Check the engine oil level and fill as necessary.

Weekly

- Remove the cover of the air filter and clean the element. Replace the element if necessary. If operating in an unusually dusty environment, check the filter daily and replace if necessary. (Replacement elements can be purchased from your local Titan dealer.)
- After each 50 hours of operation: Change the engine oil.

Spark Plug

- Use only a (NKG) BP6ES plug.
- Gap the plug 0.025" – 0.030" (0.7 – 0.8 mm).
- Make sure to use a spark plug wrench when installing and removing the plug.

Replacing the Pump ON/OFF Switch

⚠WARNING

Electrostatic discharge (ESD) potential could cause damage to electronic pressure control. Use Titan ESD wrist strap P/N 700-1037 or equivalent when working on electronic pressure control.

1. Perform the Pressure Relief Procedure.
2. Using a Phillips screwdriver, remove the four screws that secure the electronic pressure control (EPC) assembly to the EPC housing. Carefully remove the EPC assembly from the housing. Gently move the assembly away from the sprayer and allow the assembly to hang from the housing.
3. Locate the bottom of the pump ON/OFF switch inside the EPC housing.

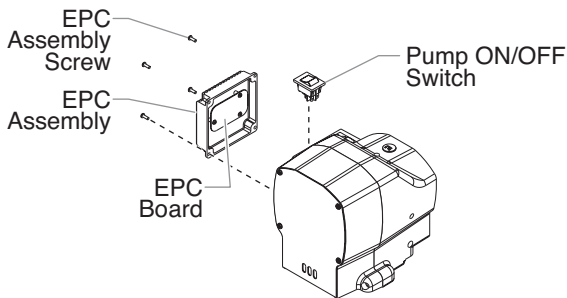

4. Disconnect the switch wires from the pump ON/OFF switch. Remember the locations of each of the two wires (label the wires, if necessary).
5. Depress the mounting tabs on each corner of the pump ON/OFF switch inside the EPC housing and remove the switch through the top of the housing.
6. Snap the new pump ON/OFF switch into the switch hole in the EPC housing.
7. Connect the two switch wires to the new pump ON/OFF switch. Make sure the wires are connected to the corresponding terminals from which they were removed (refer to the labels created earlier in this procedure or the electrical schematic in the Parts List section of this manual).
8. Carefully place the EPC assembly over the EPC housing taking care not to pinch any wires.
9. Install the four screws that secure the EPC assembly to the EPC housing. Tighten securely.

Replacing the Gears and/or Slider Assembly

1. Using a Phillips screwdriver, remove the four front cover screws. Remove the front cover.
2. Start the engine (refer to the procedures in the Operation section of this manual). Turn the pressure control knob clockwise to its maximum pressure setting.
3. Toggle the pump ON/OFF switch between the ON and OFF positions in short bursts until the slider assembly and piston stop at the bottom of their stroke (in their lowest position).
4. Turn off the engine and perform the Pressure Relief Procedure.

NOTE: If replacing the slider assembly, the fluid section must be removed from the pump housing.

5. Using a 11/16" open-end wrench, loosen and remove the fluid hose from the fitting on the back of the fluid section.
6. Using a 3/8" hex wrench, remove the two socket screws that secure the fluid section to the pump housing.
7. Remove the fluid section by pulling it straight down from the pump housing until the dowel pins on the pump housing disengage from the fluid section housing. Then, pull the fluid section forward to disengage the piston from the T-slot on the slider assembly.
8. Using a 1/4" hex wrench, remove the four socket screws that secure the pump housing to the gear housing.
9. Slide the pump housing away from the gear housing.
10. Remove and clean the housing gasket. Replace if damaged.
11. Slide the crankshaft assembly, with the two thrust washers out from the gear housing side of the pump housing.
12. Remove the output gear assembly with the two thrust washers.
13. Thoroughly clean the crankshaft assembly, the output gear assembly, and all the thrust washers.

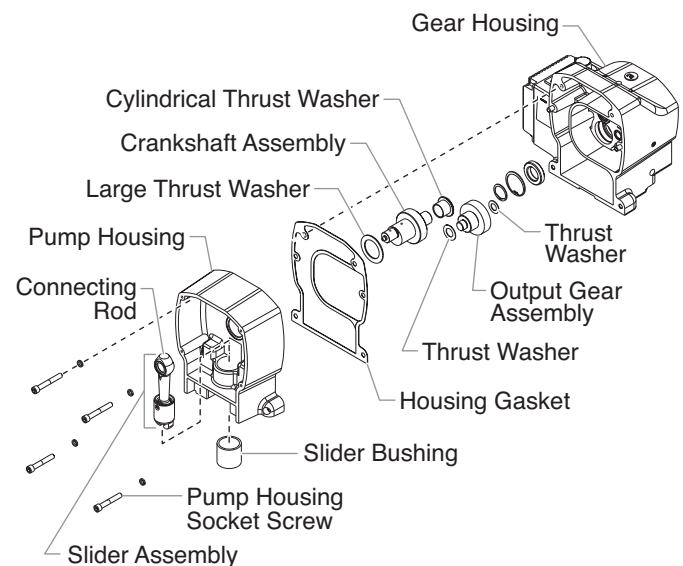
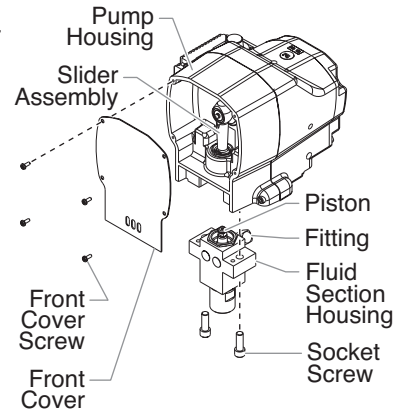

14. Inspect all parts for excessive wear and replace if damaged or worn. If the crankshaft or output gear assembly are replaced, replace the corresponding thrust washers as well.
15. Inspect the pinion gear on the end of the drive shaft for wear. Replace if damaged or worn (refer to the "Servicing the Clutch Assembly" procedure in this section).

NOTE: If any of the gears are worn and require replacement, check the grease in the gear housing for metal particles or shavings. Remove the contaminated grease. Replace the grease that has been removed with fresh Lubriplate GR-132 grease.

16. Slide the slider assembly up and out of the slider bushing in the front of the pump housing.
17. Check the parts for wear.
 - a. If the slider bushing is scored or out of round it should be replaced.
 - b. If the slider assembly is scored or the connection between the connecting rod and slider assembly exhibits movement other than pivoting movement, the slider assembly should be replaced. The slider assembly also should be replaced if the connecting rod bearing shows signs of wear.
 - c. Any parts that will be reused should be cleaned thoroughly, including the connecting rod. Also, clean the crankshaft pin that the connecting rod bearing rides on.
 - d. If the slider bushing requires replacement, a press must be used. Position the pump housing so that the bushing is facing the arbor on the press. Position the new bushing on top of the old bushing. Lower the arbor on the press to contact the new bushing and press the new bushing into the bore. As the new bushing is pressed into the bore, the old bushing is pressed out of the bore. The new bushing is in place when it is flush with the bore wall on the pump housing.
18. Coat the output gear assembly and each side of its thrust washers with fresh Lubriplate GR-132 grease. Place the thrust washers on their proper shaft of the output gear assembly.
19. Lubricate the output gear assembly with fresh Lubriplate GR-132 grease. Insert the gear assembly into its bore in the gear housing, gear end first. The teeth on the gear will mate with the teeth on the drive shaft pinion.
20. Generously coat all surfaces of the cylindrical crankshaft assembly thrust washer with fresh Lubriplate GR-132 grease.
21. Slip the flat end of the cylindrical thrust washer behind the gear on the output gear assembly, lining its bore up with the gear housing bearing bore for the crankshaft assembly.
22. Lubricate the crankshaft assembly gear with fresh Lubriplate GR-132 grease. Slide the gear side shaft of the crankshaft through the cylindrical thrust washer and into its bore within the gear housing.
23. Position the pin on the end of the crankshaft towards the bottom of the gear housing (the bottom dead center position).
24. Lubricate both faces of the large crankshaft assembly thrust washer with fresh Lubriplate GR-132 grease. Place the thrust washer onto the crankshaft against the gear.
25. Place the housing gasket over the gear housing dowel pins.
26. Lubricate the outside of the slider assembly and the inside of the slider bushing with oil. Fill the slider cup with Lubriplate 1242 grease (the slider cup is the area on the slider assembly where the connecting rod and slider join and pivot).
27. Insert the slider assembly into the slider bushing so that the small dimple on the face of the connecting rod faces the open side of the pump housing.
28. Carefully place the pump housing assembly in front of the gear housing assembly, lining up the gear housing dowel pins with their corresponding holes in the pump housing. Slide the pump housing onto the gear housing until there is no gap between the housings and gasket.

NOTE: While sliding the pump housing into place, the crankshaft pin will begin to protrude from the bearing in the center of the pump housing. Position the slider assembly so that as the crankshaft pin protrudes from the main bearing, it engages the connecting rod bearing.

⚠ CAUTION

Do not force the pump housing and gear housing together.

29. Locate the four socket screws and lock washers that secure the pump housing to the gear housing. The longer screws (2.25") are fastened into the top internal holes. The shorter screws (2") are fastened into the bottom external bosses.
30. Using a 1/4" hex wrench, snug and tighten the socket screws in a crossing pattern. Torque to 200–230 in./lbs.
31. If the fluid section was removed, reinstall by engaging the notch in the top of the piston with the groove in the bottom of the slider assembly. Push the fluid section up toward the pump housing until the dowel pins in the pump housing engage the holes in the fluid section housing.
32. Insert the two socket screws that secure the fluid section to the pump housing and alternately snug, tighten, and torque the screws to 400-440 in./lbs.
33. Position the front cover over the pump housing. Secure the front cover using the four front cover screws.
34. Using a 11/16" open-end wrench, attach the fluid hose to the fitting on the back of the fluid section. Tighten securely.

Replacing the Electronic Pressure Control (EPC) Assembly

⚠ WARNING

Electrostatic discharge (ESD) potential could cause damage to electronic pressure control. Use Titan ESD wrist strap P/N 700-1037 or equivalent when working on electronic pressure control.

1. Perform the Pressure Relief Procedure.
2. Using a Phillips screwdriver, remove the four screws that secure the electronic pressure control (EPC) assembly to the EPC housing. Carefully remove the EPC assembly from the housing. Gently move the assembly away from the sprayer and allow the assembly to hang from the housing.
3. Remember the locations of all the wire connections on the EPC board (refer the electrical schematic located in the Parts List section of this manual). If necessary, label all the connections so that they can be replaced in their exact location when the assembly is replaced.
4. Disconnect all the wires from the EPC board.
5. Connect all the wires to the new EPC assembly board (refer to the labels created earlier in this procedure or the electrical schematic in the Parts List section of this manual).
6. Carefully place the EPC assembly over the EPC housing taking care not to pinch any wires.
7. Install the four screws that secure the EPC assembly to the EPC housing. Tighten securely.
8. Take the sprayer to a Titan Authorized Service Center for re-calibration.

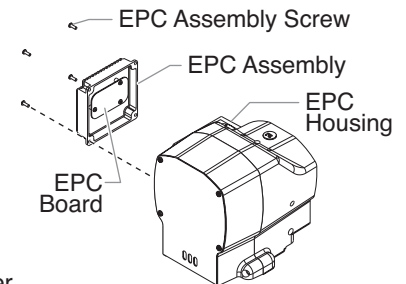

Replacing the Transducer

WARNING

Electrostatic discharge (ESD) potential could cause damage to electronic pressure control. Use Titan ESD wrist strap P/N 700-1037 or equivalent when working on electronic pressure control.

1. Perform the Pressure Relief Procedure.
2. Using a Phillips screwdriver, remove the four screws that secure the electronic pressure control (EPC) assembly to the EPC housing. Carefully remove the EPC assembly from the housing. Gently move the assembly away from the sprayer and allow the assembly to hang from the housing.
3. Locate the transducer wire in the EPC housing. This wire will be protruding from a hole in the lower left hand corner of the EPC housing. Disconnect this wire from the EPC board (it has a phone jack-style connector).
4. Break off the locking tab from the phone jack-style connector at the end of the transducer wire.
5. Using a 7/8" open-end wrench, loosen and remove the fluid hose from the fitting on the bottom of the filter assembly.
6. Remove the return hose from the fitting on the bottom of the filter assembly.
7. Using a 1/2" socket, remove the two hex screws that secure the filter assembly to the cart.
8. Lift the filter assembly off the cart so that the transducer tube moves out of the hole in the gear housing. Gently pull the transducer wire through the housing until it is fully disengaged from the hole.
9. Mount the filter assembly in a vise for easy access to the transducer.

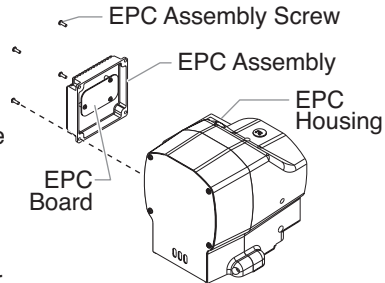

CAUTION

Do not over-tighten the vise.

10. Using a 3/4" open-end wrench, turn the transducer nut counterclockwise to remove the transducer from the filter housing.
11. Locate the new transducer. Make sure that there is a white, PTFE o-ring on the end of the transducer that gets inserted into the filter housing.
12. Insert the transducer into the filter housing port. Rotate the transducer nut clockwise to tighten it into the filter housing. Torque the nut to 360–400 in./lbs.
13. Remove the filter assembly from the vise.

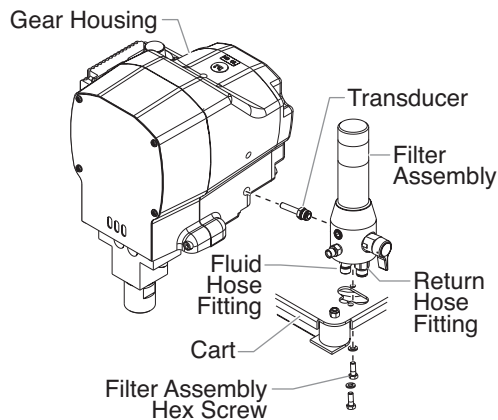

14. Insert the phone jack-style connector on the new transducer wire into the hole in the gear housing from which the old transducer wire was removed. Push the wire and connector until the connector is visible in the EPC housing.
15. Gently pull the wire into the EPC housing while moving the filter assembly to its mounting point on the cart. Guide the end of the transducer tube into the hole in the gear housing.
16. Mount the filter assembly to the cart using the two hex screws and lock washers. Torque the screws to 100–130 in./lbs.
17. Using a 7/8" open-end wrench, attach the fluid hose to the fitting on the bottom of the filter assembly. Tighten securely.
18. Push the return hose firmly into the fitting on the bottom of the filter assembly. Pull on the hose to make sure it has engaged within the fitting.
19. Plug the phone jack-style connector on the transducer wire into the socket on the EPC board from which the old connector was removed.
20. Carefully place the EPC assembly over the EPC housing taking care not to pinch any wires.
21. Install the four screws that secure the EPC assembly to the EPC housing. Tighten securely.
22. Take the sprayer to a Titan Authorized Service Center for re-calibration.
23. After re-calibration, pressurize the system and check for leaks.

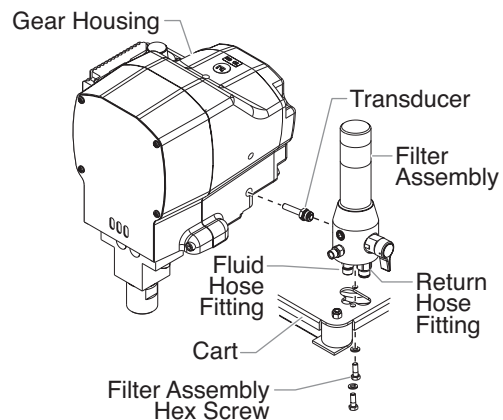

Servicing the Clutch Assembly

NOTE: When replacing the clutch armature, the clutch rotor must be replaced also. This will allow for even wear and maximum life on clutch parts.

Removing/Replacing the Clutch Armature Assembly

1. Perform the Pressure Relief Procedure.
2. Using a 11/16" open-end wrench, loosen and remove the fluid hose from the fitting on the back of the fluid section.
3. Hold the transducer tube with a pliers to prevent it from rotating and turn the transducer nut counterclockwise using a 3/4" open-end wrench. When the nut disengages the filter housing, carefully remove the transducer from the filter housing.
4. Locate the wire that exits the rear of the electronic pressure control (EPC) housing and connects to the wire harness on the engine. Disconnect this wire from its connector at the engine wire harness.
5. Using a 1/2" wrench, remove the four hex screws and lock washers that secure the clutch housing to the gear housing.
6. Using a 9/16" socket, remove the two hex screws that secure the gear housing to the cart.

- Slide the pump and gear housings away from the engine to disengage them from the clutch housing.

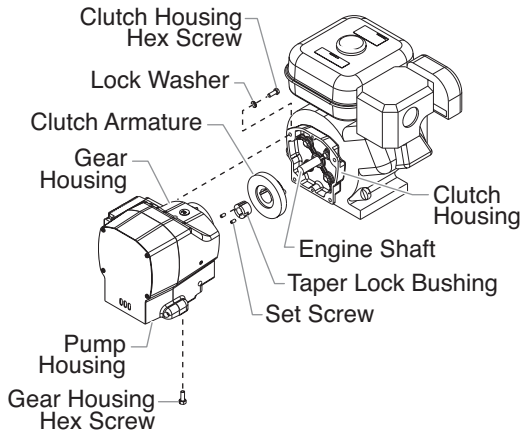

- Locate the clutch armature assembly on the end of the engine shaft. Note the two set screws as well as the unused, threaded hole in the taper lock bushing at the center of the clutch hub.
- Using an 1/8" hex wrench, remove the two set screws from the taper lock bushing.
- Thread one of the set screws into the unused, threaded hole on the taper lock bushing. As the screw tightens, the bushing will loosen. Once the bushing has loosened enough, slide the clutch armature assembly off the engine shaft.
- To replace the clutch armature assembly, line up the three holes in the taper lock bushing with the three holes in the clutch armature and insert the bushing into the center of the clutch armature.
- Line up the key on the taper lock bushing with the keyway on the engine shaft and slide the assembly onto the shaft with the holes facing out.
- Apply blue Loctite to the two set screws and insert the screws into the taper lock bushing. Tighten the set screws only two turns at this time.
- Using the clutch set-up tool (P/N 755-194), position the clutch armature on the engine shaft. Hold the tool across the face of the clutch housing so that the center, recessed portion of the tool straddles the clutch armature assembly. Pull the clutch armature assembly towards the tool until the face of the armature is against the tool.
- While holding the clutch armature assembly against the tool, use an 1/8" hex wrench and alternately tighten the set screws into the taper lock bushing. Torque to 65–75 in/lbs.
- Make sure the friction surface of the clutch armature is clean and free from oil or grease.

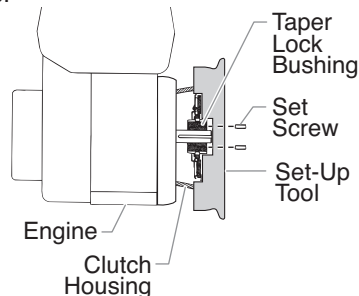

Removing the Clutch Rotor, Clutch Field, and Drive Shaft Assembly

- Follow steps 1–7 in "Removing/Replacing the Clutch Armature Assembly."
- Locate the clutch rotor assembly, which will be protruding out from the gear housing. Note the locations of the three socket screws and the two empty, threaded holes on the clutch rotor.
- Using a 3/16" hex wrench, remove the three socket screws and lock washers that secure the clutch rotor to the drive shaft assembly.
- Thread two of the socket screws into the empty, threaded holes and tighten alternately. This will push the clutch rotor away from the drive shaft assembly and pinion.

⚠ WARNING

Electrostatic discharge (ESD) potential could cause damage to electronic pressure control. Use Titan ESD wrist strap P/N 700-1037 or equivalent when working on electronic pressure control.

- Using a Phillips screwdriver, remove the four screws that secure the EPC assembly to the EPC housing. Carefully remove the EPC assembly from the housing.
- Locate the two clutch field wires that pass from the gear housing into the EPC housing through a grommet in the back of the EPC housing. Remember the wire connection terminals on the EPC assembly (label if necessary) and disconnect the wires. Gently move the EPC assembly away from the housing and rest it on the work surface by the control housing.
- Locate the four pairs of set screws that secure the clutch field to the gear housing. They are located on the exterior of the gear housing at the 12, 3, 6, and 9 o'clock positions while facing the clutch field end of the gear housing. Using an 1/8" hex wrench, remove the setscrews. Remember the location of the two clutch field wires with respect to the grommet and EPC housing.
- Carefully slide the clutch field out of the gear housing, keeping the field square to the gear housing so it does not bind.

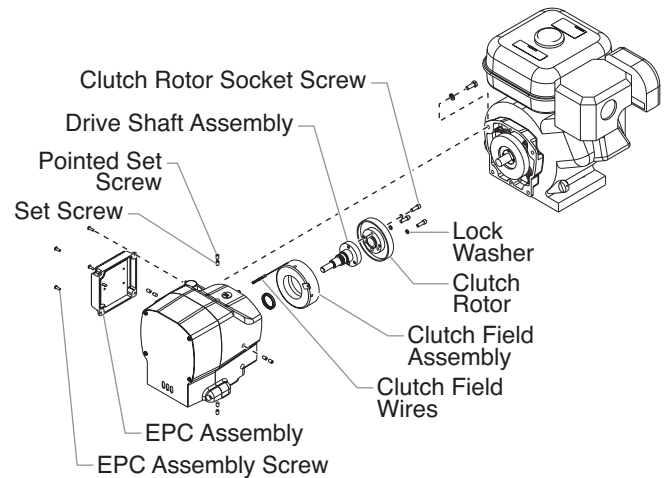

NOTE: To remove the drive shaft assembly, the pump housing first must be removed from the gear housing.

- Using a Phillips screwdriver, remove the four front cover screws. Remove the front cover.
- Using a 11/16" open-end wrench, loosen and remove the fluid hose from the fitting on the back of the fluid section.
- Using a 1/4" hex wrench, remove the four socket screws that secure the pump housing to the gear housing.
- Slide the pump housing away from the gear housing.
- Remove and clean the housing gasket. Replace if damaged.
- Locate the drive shaft pinion that is protruding from the front side of the gear housing. Remove the small snap ring that is located on the drive shaft hub in front of the ball bearing that is supporting the drive shaft.
- From the opposite side of the gear housing (clutch side) slide the drive shaft assembly out of the gear housing.
- Inspect the grease seal located inside the bore from which the drive shaft was removed. Replace if worn or damaged. To remove the grease seal, use a flat blade screwdriver to carefully pry the seal from the bore.
- Clean the inside of the gear housing.

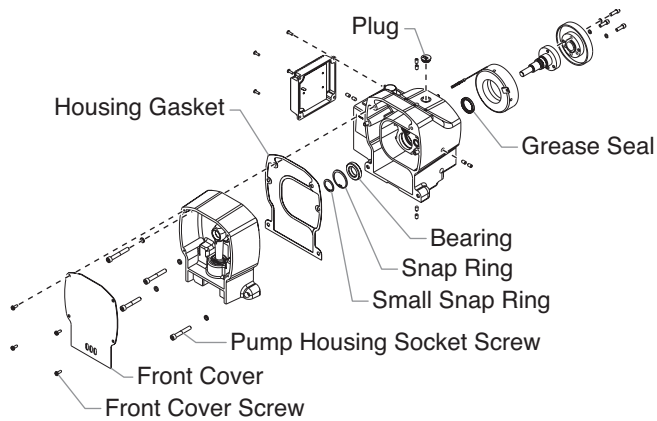

Installing the Clutch Rotor Assembly, Clutch Field and Drive Shaft Assembly

1. If the drive shaft grease seal was removed, press a new seal into the bore from which the old seal was removed.
2. From the clutch side of the gear housing, insert the drive shaft assembly into the bore, through the grease seal, and through the ball bearing on the gear side of the gear housing.
3. From the gear side of the gear housing, insert the snap ring into the groove on the drive shaft hub in front of the ball bearing.
4. Place the housing gasket over the gear housing dowel pins.
5. Carefully place the pump housing assembly in front of the gear housing assembly, lining up the gear housing dowel pins with their corresponding holes in the pump housing. Slide the pump housing onto the gear housing until there is no gap between the housings and gasket.

CAUTION

Do not force the pump housing and gear housing together.

6. Locate the four socket screws and lock washers that secure the pump housing to the gear housing. The longer screws (2.25") are fastened into the top internal holes. The shorter screws (2") are fastened into the bottom external bosses.
7. Using a 1/4" hex wrench, snug and tighten the socket screws in a crossing pattern. Torque to 200–230 in./lbs.
8. Line up the four holes around the outside of the clutch field with the four set screw holes in the gear housing. The clutch field wires should be at approximately the 1 or 2 o'clock position.
9. Route the two clutch field wires through the grommet and into the EPC housing.
10. Carefully slide the clutch field into its bore in the gear housing until it "bottoms out" within the housing. Do not pinch the clutch field wires during installation.
11. Thread one of the pointed set screws into its hole. Using an 1/8" hex wrench, rotate the screw slowly until it contacts the clutch field. **Do not tighten the set screw.** The tip of the set screw should mate with the drill point hole in the field. Check the clutch field for rotation. If it rotates within its bore, the set screw is not seated within the drill point.
12. When the set screw is properly seated, install the remaining three pointed set screws. **Do not tighten the set screws.**
13. Using a crossing pattern, tighten each of the pointed setscrews until they are snug. Once all four pointed set screws are snug, use a crossing pattern to tighten and torque the set screws to 60–70 in./lbs.

CAUTION

It is very important to evenly snug, tighten, and torque the clutch field pointed set screws in a crossing pattern. This ensures the clutch field will stay centered in the gear housing.

14. Install the remaining four set screws over the four pointed set screws. Using an 1/8" hex wrench, tighten each of the set screws in a crossing pattern until they are snug. Once all four set screws are snug, use a crossing pattern to tighten and torque the set screws to 60–70 in./lbs.
15. Line up the three screw holes and dowel pin hole on the clutch rotor with the screw holes and dowel pin on the drive shaft assembly hub. Place the clutch rotor onto the hub.
16. Using a 3/16" hex wrench, thread the three socket screws and lock washers through the clutch rotor and into the drive shaft assembly hub. Evenly snug, tighten, and torque the socket screws to 75–85 in./lbs.
17. Make sure the friction surface of the clutch rotor is clean and free from oil or grease.

WARNING

Electrostatic discharge (ESD) potential could cause damage to electronic pressure control. Use Titan ESD wrist strap P/N 700-1037 or equivalent when working on electronic pressure control.

18. Locate the two clutch field wires in the EPC housing. Gently pull the wires fully into the EPC housing so that there is no slack in the gear housing. Connect the wires to their proper terminals on the EPC board (refer to the labels created earlier in this procedure or the electrical schematic in the Parts List section of this manual).
19. Carefully place the EPC assembly over the EPC housing taking care not to pinch any wires.
20. Install the four screws that secure the EPC assembly to the EPC housing. Tighten securely.

Mating the Gear Housing and the Clutch Housing

1. Place the gear housing assembly onto the cart in front of the clutch housing. Line up the dowel pins in the gear housing with their corresponding holes in the clutch housing. Slide the gear housing assembly onto the clutch housing until there is no gap between the housings.
2. Thread the four hex screws and lock washers through the clutch housing and into the gear housing.
3. Using a 1/2" wrench, snug and tighten the hex screws in a crossing pattern. Torque to 140–155 in./lbs.
4. Using a 9/16" socket, thread the two hex screws that secure the gear housing to the cart through the underside of the cart and into the gear housing. Torque to 100–120 in./lbs.
5. Connect the wire from the EPC housing to its mating connector on the engine wire harness.
6. Make sure that there is a white PTFE o-ring on the end of the transducer that gets inserted into the filter housing. Insert the transducer into the filter housing port.
7. Hold the transducer tube with a pliers to prevent it from rotating, and turn the transducer nut clockwise with a 3/4" open-end wrench to tighten it into the filter housing. Torque the nut to 360–400 in./lbs.

Checking the Clutch Gap

1. Remove the plastic plug from the top of the clutch housing. Look through the port to locate the clutch armature and the clutch rotor.
2. Check the gap between the clutch armature and the clutch rotor using a .016" feeler gauge and a .035" feeler gauge.
 - a. Insert each feeler gauge through the port and into the gap between the clutch armature and the clutch rotor. The .016" feeler gauge should fit in the gap. The .035" feeler gauge should not fit in the gap.
 - b. Pull the engine pull cord several times to rotate the clutch armature, checking the gap with each feeler gauge between each pull.
 - c. If the .016" gauge does not fit or the .035" gauge does fit at any checkpoint, the gap must be readjusted. This is done by relocating the clutch hub and armature assembly on the engine shaft. Refer to the "Removing/Replacing the Clutch Armature Assembly" procedure.

Servicing the Fluid Section

Use the following procedures to service the valves and repack the fluid section.

1. Using a Phillips screwdriver, remove the four front cover screws. Remove the front cover.
2. Start the engine (refer to the procedures in the Operation section of this manual). Turn the pressure control knob clockwise to its maximum pressure setting.
3. Toggle the pump ON/OFF switch between the ON and OFF positions in short bursts until the slider assembly and piston rod stop at the bottom of their stroke (in their lowest position).
4. Turn off the engine and perform the Pressure Relief Procedure.

WARNING

Before proceeding, follow the Pressure Relief Procedure outlined previously in this manual. Additionally, follow all other warnings to reduce the risk of an injection injury, injury from moving parts or electric shock.

Servicing the Valves

The design of the fluid section allows access to the inlet valve and seat as well as the outlet valve and seat without completely disassembling the fluid section. It is possible that the valves may not seat properly because of debris stuck in the inlet valve seat or outlet valve seat. Use the following instructions to clean the valves and reverse or replace the seats.

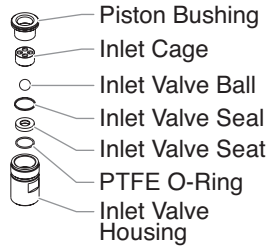
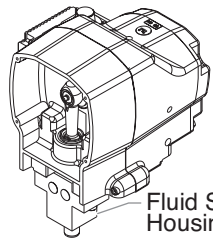

NOTE: Keep the sprayer in the upright position for this procedure.

1. Using a wrench, loosen and remove the inlet valve housing from the fluid section housing.
2. Clean out any debris in the inlet valve housing and examine the valve housing and seat. If the inlet valve seat is damaged, reverse the seat to the unused side or replace the seat.

NOTE: If the inlet valve seat is reversed or replaced, the inlet valve ball must be replaced.

3. Using a 3/8" hex wrench, loosen and remove the outlet valve retainer from the piston rod.

NOTE: Always service the outlet valve with the piston rod attached to the pump. This will prevent the piston rod from rotating during disassembly of the outlet valve.

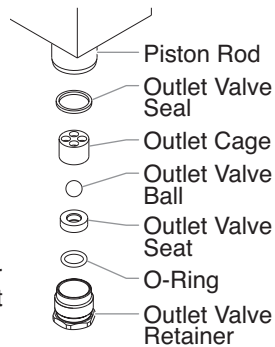

4. Clean out any debris and examine the outlet valve retainer and seat. If the outlet valve seat is damaged, reverse to the unused side or replace the seat.

NOTE: If the outlet valve seat is reversed or replaced, the outlet valve ball must be replaced.

5. Remove, clean, and inspect the outlet cage and outlet valve ball. Replace if they are worn or damaged.
6. Reassemble the valves by reversing the steps above.

Repacking the Fluid Section

NOTE: The factory-installed packings are red in color. The replacement packings in the packing replacement kit are white.

1. Remove the inlet valve and outlet valve assemblies using the steps in the "Servicing the Valves" procedure above.
2. Using a 11/16" open-end wrench, loosen and remove the fluid hose from the fitting on the back of the fluid section.
3. Using a 3/8" hex wrench, remove the two socket screws that secure the fluid section to the pump housing.
4. Remove the fluid section by pulling it straight down from the pump housing until the dowel pins on the pump housing disengage from the fluid section housing. Then, pull the fluid section forward to disengage the piston from the T-slot on the slider assembly.
5. Slide the piston rod out through the bottom of the fluid section housing.
6. Using a wrench, loosen and remove the retainer nut and piston guide from the fluid section housing.
7. Remove the upper and lower packings from the fluid section housing.

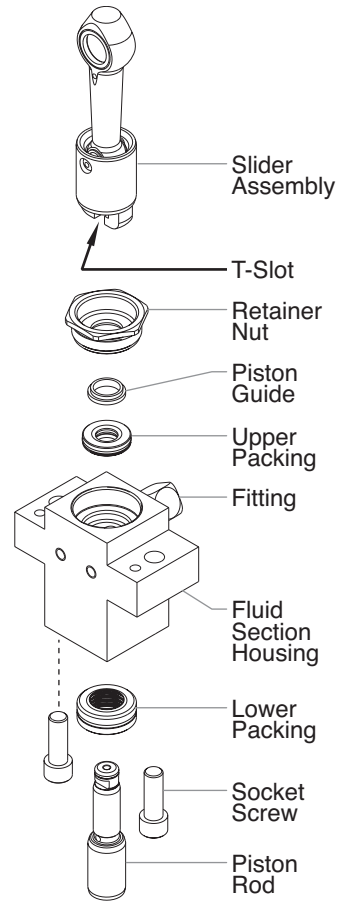

NOTE: Be careful not to scratch, score, or otherwise damage the inside of the fluid section housing during removal of the packing assemblies.

8. Clean the fluid section housing thoroughly.
9. Locate the new upper and lower packing assemblies. Remove the piston insertion tool from the upper packing and the seal sizing tool from the lower packing.
10. Pack the areas between the packing lips with grease (included in repacking kit). Lubricate the o-rings on the exterior of the packings with grease.
11. Insert the upper packing assembly into the top of the fluid section housing with the raised lip facing down into the housing.
12. Insert the lower packing assembly into the bottom of the fluid section housing with the large beveled edge facing toward the housing (beveled edge will be facing up when the housing is upright).
13. Inspect the piston rod for wear and replace if necessary.

Install upper packing with raised lip facing down.

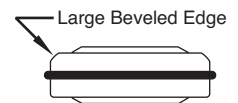
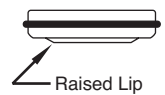

Install lower packing so large beveled edge will be facing up when the fluid section housing is upright.

- 14 Reassemble the outlet valve assembly into the piston rod using the new o-ring, outlet valve seal, and outlet valve ball that came with the repacking kit. Apply blue Loctite to the threads of the outlet valve retainer. Torque the outlet valve retainer to 150 in./lbs.

NOTE: Use the T-slot on the slider assembly to hold the piston rod in position while securing the outlet valve retainer.

CAUTION

Never use a wrench on the piston rod itself. This could cause damage to the piston and cause leakage.

15. Insert the new piston guide into the retainer nut. Thread the retainer nut into the fluid section housing until it is hand tight.
16. Slide the piston guide tool (included in the repacking kit) over the top of the piston rod.

NOTE: Coat the piston guide tool and the piston rod with grease before inserting them into the fluid section housing.

17. Insert the piston rod into the bottom of the fluid section housing, through the lower packing, through the upper packing, and out through the retainer nut. Using a rubber mallet, tap the bottom of the piston rod lightly until the piston rod is in position in the fluid section housing.

NOTE: Make sure the raised lip on the bottom of the lower packing assembly is fully outside the packing around the piston rod after insertion of the piston rod.

18. Using a wrench, tighten the retainer nut. Torque to 550-600 in./lbs.
19. Slide the top of the piston rod into the T-slot on the slider assembly.
20. Position the fluid section underneath the pump housing by lining up the pump housing dowel pins with their respective holes in the top of the fluid section housing. Push the fluid section up towards the pump housing, engaging the dowel pins, until the fluid section housing rests against the pump housing.
21. Insert the two socket screws that secure the fluid section to the pump housing and alternately snug, tighten, and torque the screws to 400-440 in./lbs.
22. Reassemble the inlet valve using the new inlet valve seal, o-ring, and inlet valve ball. Thread the inlet valve assembly into the fluid section housing and torque to 350-400 in./lbs.
23. Position the front cover over the pump housing. Secure the front cover using the four front cover screws.
24. Using a 11/16" open-end wrench, attach the fluid hose to the fitting on the back of the fluid section. Tighten securely.
25. Turn on the sprayer by following the procedure in the "Operation" section of this manual and check for leaks.

NOTE: Repacking kit P/N 755-165 is available. For best results use all parts supplied in this kit.

Replacing the Filter

1. Loosen and remove the filter body by hand.
2. Remove the filter and core spring from the filter housing.
3. Remove the core spring from inside the filter.
4. Inspect the filter. Based on inspection, clean or replace the filter.
5. Inspect the filter housing o-ring. Based on inspection, clean or replace the o-ring.
6. Slide the new or cleaned filter over the core spring with the filter spring adapter in place. Place the filter and core spring into the center of the filter housing.
7. Clean the inside of the filter body.
8. Slide the filter body over the filter and thread it into the filter housing until secure.

NOTE: The filter body should be hand-tightened, but make sure it is seated fully into the filter housing.

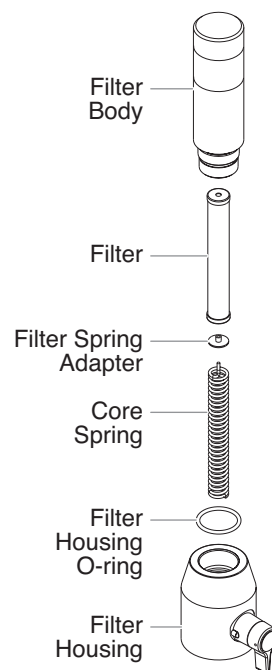

Replacing the PRIME/SPRAY Valve

Perform the following procedure using PRIME/SPRAY valve replacement kit P/N 800-915.

1. Drive the groove pin out of the valve handle.
2. Remove the valve handle and the cam base.
3. Using a wrench, loosen and remove the valve housing assembly.
4. Make sure the gasket is in place and thread the new valve housing assembly into the filter housing. Tighten securely with a wrench.
5. Place the cam base over the valve housing assembly. Lubricate the cam base with grease and line up the cam with the filter block using the dowel pin.
6. Line up the hole on the valve stem with the hole in the valve handle.
7. Insert the groove pin into the valve handle and through the valve stem to secure the valve handle in position.

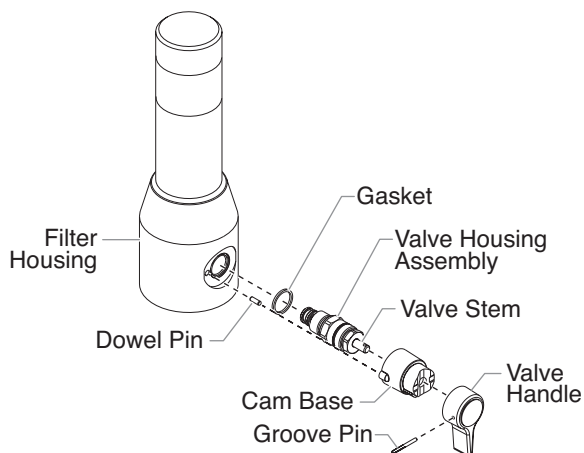

Replacing the Potentiometer

⚠ WARNING

Electrostatic discharge (ESD) potential could cause damage to electronic pressure control. Use Titan ESD wrist strap P/N 700-1037 or equivalent when working on electronic pressure control.

1. Perform the Pressure Relief Procedure.
2. Pry off the pressure control knob cap to expose the knob tension nut.
3. Turn the pressure control knob fully counterclockwise to the minimum pressure setting.
4. Using a 5/16" socket, loosen the tension nut in the center of the knob. Remove the knob.
5. Using a Phillips screwdriver, remove the four screws that secure the electronic pressure control (EPC) assembly to the EPC housing. Carefully remove the EPC assembly from the housing. Gently move the assembly away from the sprayer and allow the assembly to hang from the housing.

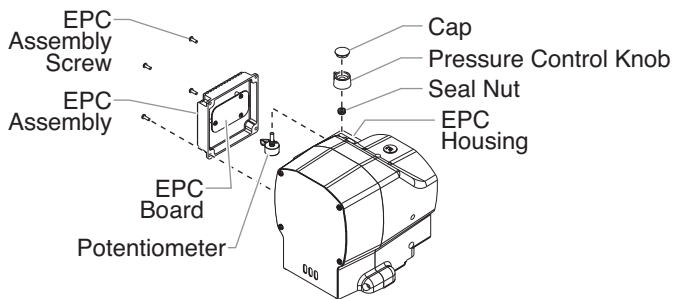

6. Hold the potentiometer inside the EPC housing while using a 1/2" thin wall socket to remove the seal nut that secures the potentiometer to the mounting plate. Remove the potentiometer from the EPC housing.
7. Carefully remove the potentiometer wires from their connection point on the EPC board.
8. Insert the stem of the new potentiometer through the hole in the mounting plate from inside the EPC housing. Position the protruding tab on the potentiometer face into the hole on the underside of the mounting plate (the wires will face the open side of the EPC housing).
9. Thread the seal nut onto the threaded portion of the stem and tighten using a 1/2" thin wall socket.

⚠ CAUTION

Do not over-tighten the seal nut.

10. Turn the potentiometer stem fully counterclockwise.
11. Place the pressure control knob on the potentiometer stem with the indicator tab resting at the "minimum pressure" tab on the mounting plate.
12. Tighten the knob tension nut using a 5/16" socket.

⚠ CAUTION

Do not over-tighten the knob tension nut. Over-tightening will damage the potentiometer.

13. Connect the potentiometer wires to the EPC board. The protruding tab on the EPC board connector will mate with the slot on the potentiometer wires connector. The connector on the end of the potentiometer wires and the connector on the EPC board will mate only one way. Do not force the connectors together.
14. Carefully place the EPC assembly over the EPC housing taking care not to pinch any wires.
15. Install the four screws that secure the EPC assembly to the EPC housing. Tighten securely.

Accessories

Liquid Shield Plus

Cleans and protects spray systems against rust, corrosion and premature wear.

Part No.	Description
314-483	4 ounce bottle
314-482	1 quart bottle



Piston Lube

Specially formulated to prevent materials from adhering to the piston rod, which becomes abrasive to the upper seals. Piston Lube will break down any material that may accumulate in the wet cup and keep it from drying.

Part No.	Description
314-481	4 ounce bottle
314-480	8 ounce bottle



Miscellaneous

Part No.	Description
730-397	High-pressure fluid Gauge
314-171	Lubriplate, 14 ounce individual
314-172	Lubriplate, 6 lb. can
700-1037	Electrostatic discharge (ESD) wrist strap

Troubleshooting

Problem

Cause

Solution

The unit will not run.

1. The pressure is set too low.
2. Faulty or loose wiring.
3. The gas tank is empty.

1. Turn the pressure control knob clockwise to supply power to the unit and increase the pressure setting.
2. Inspect or take to a Titan authorized service center.
3. Fill the gas tank.

The unit will not prime.

1. The PRIME/SPRAY valve is in the SPRAY position.
2. Air leak in the siphon tube/suction set.
3. The pump filter and/or inlet screen is clogged.
4. The siphon tube/suction set is clogged.

1. Rotate the PRIME/SPRAY valve clockwise to the PRIME position.
2. Check the siphon tube/suction set connection and tighten or re-tape the connection with PTFE tape.
3. Remove the pump filter element and clean. Remove the inlet screen and clean.
4. Remove the siphon tube/suction set and clean.

The unit will not build or maintain pressure.

1. The spray tip is worn.
2. The spray tip is too large.
3. The pressure control knob is not set properly.
4. The pump filter, gun filter, or inlet screen is clogged.
5. Material flows from the return hose when the PRIME/SPRAY valve is in the SPRAY position.
6. Air leak in the siphon tube/suction set.
7. There is external fluid leak.
8. There is an internal fluid section leak (packings are worn and/or dirty, valve balls are worn).
9. Worn valve seats

1. Replace the spray tip following the instructions that came with the spray gun.
2. Replace the spray tip with a tip that has a smaller orifice following the instructions that came with the spray gun.
3. Turn the pressure control knob clockwise to increase the pressure setting.
4. Remove the pump filter element and clean. Remove the gun filter and clean. Remove the inlet screen and clean.
5. Clean or replace the PRIME/SPRAY valve.
6. Check the siphon tube/suction set connection and tighten or re-tape the connection with PTFE tape.
7. Check for external leaks at all connections. Tighten connections, if necessary.
8. Clean the valves and service the fluid section following the "Servicing the Fluid Section" procedure in the Maintenance section of this manual.
9. Reverse or replace the valve seats following the "Servicing the Fluid Section" procedure in the Maintenance section of this manual.

Fluid leakage at the upper end of the fluid section.

1. The upper packings are worn.
2. The piston rod is worn.

1. Repack the pump following the "Servicing the Fluid Section" procedure in the Maintenance section of this manual.
2. Replace the piston rod following the "Servicing the Fluid Section" procedure in the Maintenance section of this manual.

Troubleshooting

Problem

Excessive surge at the spray gun.

Cause

1. Wrong type of airless spray hose.
2. The spray tip worn or too large.
3. Excessive pressure.

Solution

1. Replace hose with a minimum of 50' of 1/4" grounded textile braid airless paint spray hose.
2. Replace the spray tip following the instructions that came with the spray gun.
3. Rotate the pressure control knob counterclockwise to decrease spray pressure.

Poor spray pattern.

-
1. The spray tip is too large for the material being used.
 2. Incorrect pressure setting.
 3. Insufficient fluid delivery.
 4. The material being sprayed is too viscous.

-
1. Replace the spray tip with a new or smaller spray tip following the instructions that came with the spray gun.
 2. Rotate the pressure control knob to adjust the pressure for a proper spray pattern.
 3. Clean all screens and filters.
 4. Add solvent to the material according to the manufacturer's recommendations.

The unit lacks power.

-
1. The pressure adjustment is too low.

-
1. Rotate the pressure control knob clockwise to increase the pressure setting.

Consignes de sécurité

Le présent manuel comprend des renseignements devant être lus attentivement avant toute utilisation de l'appareil. Lorsque l'un des symboles suivants apparaît, il est recommandé d'être particulièrement attentif et de tenir compte des mesures de sécurité indiquées.

⚠ AVERTISSEMENT

Ce symbole indique un danger potentiel pouvant causer des blessures graves ou même mortelles. Des renseignements importants sur la sécurité sont également indiqués.

⚠ ATTENTION

Ce symbole indique un danger potentiel pouvant causer des blessures corporelles ou des dommages à l'équipement. Des renseignements importants sur la façon de prévenir tout dommage à l'équipement ou toute blessure corporelle mineure sont également indiqués.

NOTA : Les remarques donnent des renseignements importants requérant une attention particulière.

⚠ AVERTISSEMENT

DANGER: BLESSURES PAR PERFORATION - Le jet de peinture à haute pression produit par cet appareil peut perforer la peau et les tissus sous-jacents et entraîner de sévères blessures pouvant nécessiter une amputation. Consultez immédiatement un médecin.

NE PAS TRAITER UNE BLESSURE PAR PERFORATION COMME UNE SIMPLE COUPURE! Une perforation peut entraîner des risques d'amputation. Consultez immédiatement un médecin.

Pression de service maximale du fluide dans l'appareil : 3300 lb/po2 / 22.8 MPa.

MESURES PRÉVENTIVES:

- NE JAMAIS diriger le pistolet vers une quelconque partie du corps.
- NE JAMAIS mettre une quelconque partie du corps en contact avec le jet de liquide. NE JAMAIS se mettre au contact d'un jet de liquide provenant d'une fuite du flexible d'alimentation en liquide.
- NE JAMAIS placer votre main devant le pistolet. Des gants ne vous protégeront pas contre les risques de blessures par perforation.
- TOUJOURS verrouiller la gâchette du pistolet, fermer la pompe à liquide et décompresser l'appareil lorsque vous travaillez sur celui-ci, nettoyez le protecteur de tête, remplacez la tête de pulvérisation ou vous éloignez de l'appareil. Couper le moteur ne décompresse pas l'appareil. Vous devez, pour le décompresser, placer le bouton AMORÇAGE/PULVÉRISATION en position AMORÇAGE. Reportez-vous, pour cela, à la PROCÉDURE DE DÉCOMPRESSION décrite dans de ce manuel.
- TOUJOURS s'assurer que le protecteur de tête est en place lorsque vous pulvérisez. Le protecteur de tête offre une certaine protection contre les blessures par perforation mais sa principale fonction est d'ordre préventif.
- TOUJOURS ôter la tête de pulvérisation avant de purger ou nettoyer l'appareil.
- Le flexible d'alimentation en peinture peut fuir à la suite d'une usure, de chocs ou de mauvais traitements. Une fuite peut entraîner une perforation de la peau. Inspecter le flexible avant chaque utilisation.
- NE JAMAIS utiliser un pistolet dont la gâchette n'est pas munie d'un loquet ou un cran de sécurité qui soit en état de fonctionner.
- Tous les accessoires doivent être homologués pour une pression égale ou supérieure à 3 200 lb/po2 / 22.8 MPa. Cela s'applique, entre autres, aux têtes de pulvérisation, aux accessoires du pistolet et aux flexibles.

AVERTISSEMENT AUX MÉDECINS : Une perforation sous-cutanée constitue un traumatisme. Il est important de traiter la blessure de façon chirurgicale aussitôt que possible. NE RETARDEZ PAS ce traitement pour des recherches de toxicité. La toxicité n'est un risque que dans les cas où certains produits de revêtement pénètrent dans le flux sanguin. Il peut être nécessaire de faire appel à des soins de chirurgie plastique ou de reconstruction de la main.

DANGER: RISQUES D'EXPLOSION OU D'INCENDIE - Les vapeurs dégagées par le solvant ou la peinture sont explosives et inflammables et peuvent causer des corporels sérieux ou dommages matériels.

MESURES PRÉVENTIVES:

- Veiller à éviter toute accumulation de vapeurs inflammables en vous assurant que la zone où la pulvérisation a lieu est suffisamment ventilée.
- Veiller à éviter la présence de toute source incandescente telle qu'étincelle électrostatique, flamme nue, flamme-pilote, objet brûlant, cigarette et étincelle provenant du branchement ou du débranchement d'un cordon d'alimentation électrique ou d'un commutateur.
- Ne pas fumer dans la zone d'épandage.
- Toujours avoir un extincteur en état de fonctionner à portée de la main.
- Placer la pompe à peinture à une distance d'au moins un mètre (3 pi) (on recommande d'ailleurs une plus grande distance) de l'objet qui doit être vaporisé dans une pièce séparée bien aérée, ou à une distance d'au moins six mètres (20 pi) de celui-ci dans une zone bien aérée (utiliser d'autres tuyaux si nécessaires). Les vapeurs inflammables sont souvent plus lourdes que l'air. Le plancher doit être extrêmement bien aéré. La pompe à peinture contient des pièces pouvant créer des étincelles et enflammer les vapeurs présentes dans l'air.
- Le matériel utilisé, ainsi que les objets se trouvant à proximité de la zone de pulvérisation, doivent être convenablement reliés à la terre afin d'éviter toute étincelle ou toute décharge électrostatique.
- N'utiliser que des flexibles d'alimentation en liquide à haute pression conducteurs ou reliés à la terre dans les cas d'utilisation sans air comprimé. S'assurer que le pistolet est convenablement relié à la terre par l'intermédiaire du flexible.
- Le cordon d'alimentation doit être raccordé à un circuit mis à la terre.
- Toujours purger l'appareil dans un contenant métallique séparé, en s'assurant que la pompe soit à basse pression et que le chapeau soit retiré. Tenir le pistolet fermement contre la paroi du contenant pour mettre celui-ci à la terre et empêcher l'émission d'étincelles causées par l'électricité statique.
- Se conformer aux consignes et recommandations de sécurité du fabricant du solvant ou du produit.
- S'entourer de toutes les précautions possibles lorsqu'on utilise des produits ayant un point d'éclair inférieur à 21 °C (70 °F). Le point d'éclair d'un fluide est la température à laquelle les vapeurs émanant du fluide peuvent s'enflammer au contact d'une flamme ou d'une étincelle.
- Le plastique peut être une source d'étincelles provoquées par l'électricité statique. Ne jamais utiliser une couverture en plastique pour fermer une zone d'épandage ni utiliser des toiles de protection en plastique lors de la pulvérisation de matières inflammables.
- Lorsque vous purgez l'appareil, veillez à utiliser à la pression minimale.

MOTEUR À ESSENCE (DANS LES CAS OÙ CELA S'APPLIQUE)

Toujours placer la pompe à l'extérieur de la structure à l'air frais. Garder tous les solvants loin de l'échappement du moteur. Ne jamais remplir le réservoir à carburant lorsque le moteur est en marche ou lorsqu'il est chaud ; les surfaces chaudes risquent d'enflammer le carburant déversé accidentellement. Toujours raccorder un fil de mise à la terre entre la pompe et un objet mis à la terre, tel qu'une conduite d'eau métallique. Se reporter au guide d'utilisation du moteur pour obtenir de plus amples renseignements concernant la sécurité.

DANGER: RISQUES D'EXPLOSION PAR INCOMPATIBILITÉ DES MATÉRIAUX - Peuvent être à l'origine de corporels sérieux ou dommages matériels.

MESURES PRÉVENTIVES:

- Ne pas utiliser de matériaux contenant des agents de blanchiment ou du chlore.
- Ne pas utiliser des solvants à base d'hydrocarbure halogéné tels que l'agent anticryptogamique, le chlorure de méthylène et le trichloro-éthane-1,1,1. Ces produits ne sont pas compatibles avec l'aluminium.
- Communiquer avec votre fournisseur de revêtement pour connaître la compatibilité du matériau avec l'aluminium.

DANGER: VAPEURS NOCIVES – la peinture, les solvants, les insecticides et autres matériaux peuvent être nocifs lorsqu'ils sont inhalés ou en contact avec le corps. Les vapeurs peuvent causer une nausée importante, des évanouissements ou un empoisonnement.

MESURES PRÉVENTIVES:

- Utiliser un respirateur ou un masque chaque fois qu'il y a des risques d'inhalation de vapeurs. Lire attentivement toutes les instructions se rapportant au masque pour vérifier que celui-ci vous assure une protection suffisante contre les vapeurs toxiques.
- Porter des lunettes de protection.
- Porter des vêtements de protection, conformément aux directives du fabricant de revêtement.

DANGER: GÉNÉRALITÉS - Peut causer des dommages matériels ou corporels sérieux.

MESURES PRÉVENTIVES:

- Avant d'utiliser tout équipement, lire attentivement toutes les instructions et les consignes de sécurité.
- Toujours débrancher le moteur de l'alimentation électrique avant d'effectuer des travaux sur l'appareil.
- Se conformer à la législation locale, provinciale ou fédérale pour tout ce qui concerne la ventilation, la prévention des incendies et les conditions générales d'utilisation.
- Les normes de sécurité du Gouvernement américain sont régies par le Occupational Safety and Health Act (OSHA). Il est important de consulter ces normes, en particulier la section 1910 sur les normes générales et la section 1926 sur les des normes de la construction.
- N'utiliser que les pièces autorisées par le fabricant. L'utilisateur assume tous les risques et responsabilités lorsqu'il utilise des pièces qui ne sont pas conformes aux caractéristiques techniques minimales ainsi qu'aux dispositifs de sécurité du fabricant de la pompe.
- Vérifier, avant toute utilisation, que les flexibles ne présentent pas d'entaille ou de fuite, que le couvercle ne soit pas gonflé et que les raccords ne soient pas endommagés. Si le flexible a subi l'un des dommages précités, remplacez-le immédiatement. Ne jamais réparer un flexible d'alimentation en peinture. Le remplacer par un autre flexible mis à la terre.
- Tout flexible, raccord orientable, pistolet et accessoire utilisé avec cet appareil doit pouvoir fonctionner à une pression égale ou supérieure à 3 200 lb/po² / 22.8 MPa.
- Ne jamais pulvériser lorsqu'il vente.
- Porter des vêtements pour protéger la peau et les cheveux contre tout contact avec la peinture.

Sécurité des moteurs à essence

AVERTISSEMENT

Les produits chimiques contenus dans les vapeurs d'échappement de cet appareil sont reconnus par l'État de la Californie (États-Unis) comme étant cancérigènes. Ils peuvent également entraîner des anomalies congénitales ou d'autres dangers pour la santé.

1. Les moteurs Honda sont conçus pour fonctionner en toute sécurité et avec une fiabilité maximale s'ils sont utilisés conformément aux instructions. Veuillez lire et comprendre le manuel de l'utilisateur de Honda avant de faire fonctionner le moteur. Le non-respect de ces consignes peut entraîner des dommages matériels ou des blessures physiques graves.
2. Pour éviter tout risque d'incendie et fournir une ventilation adéquate, placez le moteur à une distance minimale de 1 mètre (3 pieds) des immeubles et d'autres équipements pendant son fonctionnement. Ne placez pas d'objets inflammables à côté du moteur.
3. Tenez les enfants et les animaux domestiques à l'écart de la zone de travail; vous éviterez ainsi tout risque de brûlures sur les pièces chaudes du moteur et de blessures entraînées par les accessoires utilisés par le moteur pour son fonctionnement.
4. Sachez comment arrêter rapidement le moteur, et assurez-vous que vous avez bien compris le fonctionnement de toutes les commandes. Ne permettez jamais à une personne de faire fonctionner le moteur sans connaître les instructions nécessaires.
5. L'essence est extrêmement inflammable et explosive dans certaines conditions.
6. Remplissez le réservoir de carburant dans une zone bien ventilée, moteur arrêté. Ne fumez pas et évitez toutes flammes ou étincelles dans la zone de remplissage de carburant ou dans une zone de stockage du carburant.
7. Veillez à ne pas faire déborder le réservoir de carburant. Après remplissage, assurez-vous que le bouchon du réservoir est solidement vissé.
8. Faites attention à ne pas renverser de carburant lors du remplissage du réservoir. Les vapeurs ou les éclaboussures de carburant peuvent s'enflammer. En cas d'éclaboussures, assurez-vous que la zone est bien sèche avant de faire démarrer le moteur.
9. Ne faites jamais fonctionner le moteur dans un endroit fermé ou confiné. Les fumées d'échappement contiennent du monoxyde de carbone qui est un gaz toxique; une exposition prolongée peut entraîner une perte de conscience et peut s'avérer mortelle.
10. Le silencieux devient très chaud pendant le fonctionnement et reste chaud quelque temps après l'arrêt du moteur. Faites attention à ne pas toucher le silencieux tant qu'il est chaud. Pour éviter des brûlures graves ou des risques d'incendie, laissez le moteur refroidir avant de le transporter ou de le ranger à l'intérieur.
11. Ne transportez jamais le moteur si le réservoir est plein.

Precauciones de seguridad

Este manual contiene información que debe leer y comprender antes de usar el equipo. Cuando se encuentre con uno de los siguientes símbolos, asegúrese de observar sus indicaciones de seguridad.

⚠ ADVERTENCIA

Este símbolo indica la existencia de un peligro potencial que puede causar lesiones graves o la muerte. Después del mismo se incluye información de seguridad importante.

⚠ PRECAUCION

Este símbolo indica la existencia de un peligro potencial para usted o el equipo. Después del mismo se incluye información importante que indica la forma de evitar daños al equipo o la forma de prevenir lesiones menores.

NOTA: los avisos contienen información importante, présteles especial atención.

⚠ ADVERTENCIA

PELIGRO: LESIÓN POR INYECCIÓN - La corriente de pintura de alta presión que produce este equipo puede perforar la piel y tejidos subyacentes, lo que conduciría a lesiones serias y una posible amputación. Consulte de inmediato a un médico.

NO TRATE LAS LESIONES POR INYECCIÓN COMO SI FUERAN SIMPLES CORTADAS! Una inyección puede conducir a una amputación. Consulte de inmediato a un médico.

El rango de operación máximo de la unidad es 3300 PSI / 22.8 MPa de presión de fluidos.

PARA PREVENIR:

- NO dirija NUNCA la punta de la pistola hacia alguna parte del cuerpo.
- NO permita NUNCA que alguna parte del cuerpo tenga contacto con la corriente del fluido. EVITE tener contacto con corrientes de fluido que salgan de fugas que haya en la manguera.
- NO ponga NUNCA la mano enfrente de la manguera. Los guantes no ofrecen ninguna protección contra lesiones por inyección.
- Bloquee SIEMPRE el gatillo de la pistola, apague la bomba de fluido y libere toda la presión antes de dar mantenimiento, limpiar el protector de la boquilla, cambiar la boquilla o dejar desatendido el equipo. La presión no se liberará al apagar el motor. Para liberar la presión debe girarse la perilla PRIME/SPRAY (cebar/atomizar) hasta la posición PRIME. Consulte el PROCEDIMIENTO PARA LIBERAR LA PRESIÓN que se describe en este manual.
- Mantenga puesto SIEMPRE el protector de la boquilla mientras atomice. El protector de la boquilla ofrece cierta protección contra lesiones por inyección pero es principalmente un dispositivo de advertencia.
- Quite SIEMPRE la boquilla del atomizador antes de enjuagar o limpiar el sistema.
- Pueden desarrollarse fugas en la manguera de pintura por causa del desgaste, retorcimientos o el abuso. Una fuga es capaz de inyectar el material en la piel. Cada vez que use la manguera de pintura, inspecciónela antes.
- NO use nunca una pistola de atomización que no tenga un bloqueador o un protector de gatillo puesto y que funcione.
- Todos los accesorios deben tener una capacidad de 3300 lb/pulg² / 22.8 MPa o mayor. Esto incluye las boquillas de atomizador, pistolas, extensiones y mangueras.

NOTA PARA EL MÉDICO: La inyección dentro de la piel es una lesión traumática. Es importante que la lesión se trate quirúrgicamente tan pronto como sea posible. NO retrase el tratamiento por investigar la toxicidad. La toxicidad es motivo de preocupación con algunos revestimientos que se inyectan directamente en la corriente sanguínea. Es recomendable consultar a un cirujano plástico o reconstructor de manos.

PELIGRO: EXPLOSIÓN O INCENDIO - Los vapores de solventes y pintura pueden explotar o incendiarse, causando con esto lesiones severas y/o daños en la propiedad.

PARA PREVENIR:

- Debe proveerse un escape y aire fresco para hacer que el aire que está dentro del área de atomización se mantenga libre de acumulaciones de vapores inflamables.
- Evite todas las fuentes de ignición como son las chispas electrostáticas, llamas abiertas, flamas de piloto, objetos calientes, cigarros, y chispas que se generan al conectar y desconectar las extensiones o de apagadores de luz que estén funcionando.
- No fume en la zona de trabajo.
- Debe haber un equipo para extinguir incendios permanentemente y en buenas condiciones.
- Coloque la bomba para pintar a un mínimo de 1 m (de preferencia más) en una habitación aparte, bien ventilada, alejada del objeto que va a pintar o a por lo menos 6 m de dicho objeto, en una zona bien ventilada (utilice una manguera más larga, si es necesario). Los gases inflamables a menudo son más pesados que el aire. La zona del piso debe tener la debida ventilación. La bomba para pintar contiene piezas que forman arcos que emiten chispas y pueden encender los gases.
- El equipo que se utilice, así como los objetos que estén dentro y alrededor del área de atomización, deben conectarse a tierra de manera apropiada para prevenir las descargas eléctricas y las chispas.
- Use solamente mangueras para fluidos de alta presión, conductoras o conectadas a tierra, para aplicaciones sin aire. Asegúrese de que la pistola esté conectada a tierra de manera apropiada, mediante conexiones de manguera.
- El cable de alimentación debe enchufarse a un circuito aterrado.
- Siempre enjuague la unidad en un recipiente de metal por separado, con presión baja en la bomba y sin la boquilla. Sostenga la pistola firmemente contra el recipiente para ponerlo a tierra y evitar chispas estáticas.
- Siga las advertencias y avisos de seguridad del fabricante de los materiales y solventes.
- Tenga muchísimo cuidado al usar materiales cuyo punto de ignición sea inferior a 70° F (21° C). El punto de ignición es la temperatura a la cual pueden encenderse los vapores emanados por un fluido al exponerlos a llamas o chispas.
- El plástico puede causar chispas estáticas. Nunca cuelgue plástico en las ventanas ni en las puertas del área donde va a pintar. No utilice plástico para proteger el piso cuando pinte materiales inflamables.
- Cuando enjuague el equipo utilice la presión más baja posible.

MOTOR DE GAS (SEGÚN CORRESPONDA)

Coloque siempre la bomba fuera del edificio, al aire libre. Mantenga todo solvente alejado del escape del motor. Nunca llene el tanque de combustible si el motor está encendido o caliente. La superficie caliente puede encender el combustible derramado. Conecte siempre un conductor de tierra desde la unidad de la bomba a un objeto puesto a tierra, por ejemplo una tubería de agua metálica. Consulte el manual del motor para obtener información completa de seguridad.

PELIGRO: PELIGRO DE EXPLOSIÓN DEBIDO A MATERIALES INCOMPATIBLES - Podría causar lesiones severas o daños en la propiedad.

PARA PREVENIR:

- No utilice materiales que contengan blanqueador o cloro.
- No use solventes con hidrocarburos halogenados, tales como productos para eliminar el moho, cloruro de metileno y 1,1,1 - tricloroetano. Estos no son compatibles con el aluminio.
- Comuníquese con el proveedor del producto para obtener información de compatibilidad con materiales de aluminio.

PELIGRO: GASES PELIGROSOS - Las pinturas, solventes, insecticidas y otros materiales pueden ser perjudiciales si se inhalan o entran en contacto con el cuerpo. Los gases pueden causar náusea, desmayos o envenenamiento graves.

PARA PREVENIR:

- Use una mascarilla respiratoria o careta siempre que exista la posibilidad de que se puedan inhalar vapores. Lea todas las instrucciones que vengan con la careta para estar seguro de que se tendrá la protección necesaria contra la inhalación de vapores dañinos.
- Use gafas protectoras.
- Use ropa de protección, según lo requiera el fabricante del producto.

PELIGRO: GENERAL - Puede causar daños en la propiedad o lesiones severas.

PARA PREVENIR:

- Lea todas las instrucciones y advertencias de seguridad antes de hacer funcionar cualquier equipo.
- Desconecte siempre el motor del suministro eléctrico antes de dar servicio al equipo.
- Observe todos los códigos locales, estatales y nacionales apropiados que rigen las medidas de ventilación, prevención de incendios y operación.
- Los Estándares de Seguridad del Gobierno de los Estados Unidos se han adoptado bajo el Acta de Seguridad y Salud Ocupacionales (OSHA por sus siglas en inglés). Deben consultarse estos estándares, particularmente la parte 1910 de los Estándares Generales y la parte 1926 de los Estándares de la Construcción.
- Utilice únicamente piezas autorizadas por el fabricante. El usuario asume todos los riesgos y responsabilidades si usa piezas que no cumplen con las especificaciones mínimas y dispositivos de seguridad del fabricante de la bomba.
- Antes de usarla cada vez, revise todas las mangueras para ver que no tengan cortadas, fugas, una cubierta desgastada por abrasión o con abolladuras, así como uniones dañadas o que se hayan movido. Si existiera cualquiera de estas condiciones, reemplace la manguera inmediatamente. No repare nunca una manguera de pintura. Reemplácela con otra manguera conectada a tierra.
- Todas las mangueras, soportes giratorios, pistolas y accesorios que se usen con esta unidad deben tener una capacidad de presión de 3300 lb/pulg² / 22.8 MPa o mayor.
- No atomice en días con viento.
- Use ropa que evite el contacto de la pintura con la piel y el cabello.

Seguridad del motor de gasolina

⚠ ADVERTENCIA

El escape del motor de esta unidad contiene productos químicos que el Estado de California reconoce que causan cáncer, defectos congénitos u otros daños a la reproducción.

1. Los motores Honda han sido diseñados para ofrecer un servicio seguro y fiable, si son manejados de acuerdo con las instrucciones. Lea y comprenda el Manual del Propietario de Honda antes de hacer funcionar el motor. Si no hace esto, podrían producirse lesiones personales o daños en el equipo.
2. Para evitar riesgos de incendio y proporcionar una ventilación adecuada, mantenga el motor como mínimo a 1 metro (tres pies) de edificios y de otros equipos durante su funcionamiento. No coloque objetos inflamables cerca del motor.
3. Los niños y los animales de compañía deben mantenerse alejados del área de trabajo, debido a la posibilidad de quemaduras producidas por los componentes calientes del motor o de daños producidos por el equipo al que haga funcionar el motor.
4. Conozca el modo de detener rápidamente el motor, y entienda el funcionamiento de todos los controles. No permita que nadie haga funcionar el motor sin las instrucciones adecuadas.
5. La gasolina es extremadamente inflamable y es explosiva en determinadas circunstancias.
6. Reabastézcase de combustible en una zona bien ventilada y con el motor apagado. No fume ni permita que haya llamas ni chispas en el área de reabastecimiento de combustible ni donde se almacene la gasolina.
7. No llene excesivamente el tanque de combustible. Tras repostar, asegúrese de que la tapa del tanque está adecuadamente cerrada y asegurada.
8. Tenga cuidado de no derramar combustible cuando realice el reabastecimiento. Los vapores del combustible o el combustible derramado pueden inflamarse. Si se derrama combustible, asegúrese de que el área esté seca antes de arrancar el motor.
9. Nunca haga funcionar el motor en un área cerrada o reducida. Los gases de escape contienen monóxido de carbono tóxico: su exposición puede causar la pérdida del conocimiento y puede originar la muerte.
10. El silenciador se calienta mucho durante el funcionamiento y permanece caliente durante un tiempo después de que el motor esté parado. Tenga cuidado de no tocar el silenciador mientras está caliente. Para evitar quemaduras graves o riesgos de incendio, deje que el motor se enfríe antes de transportarlo o almacenarlo en el interior.
11. Nunca transporte una unidad con gasolina en el tanque.

Parts List

Main Assembly

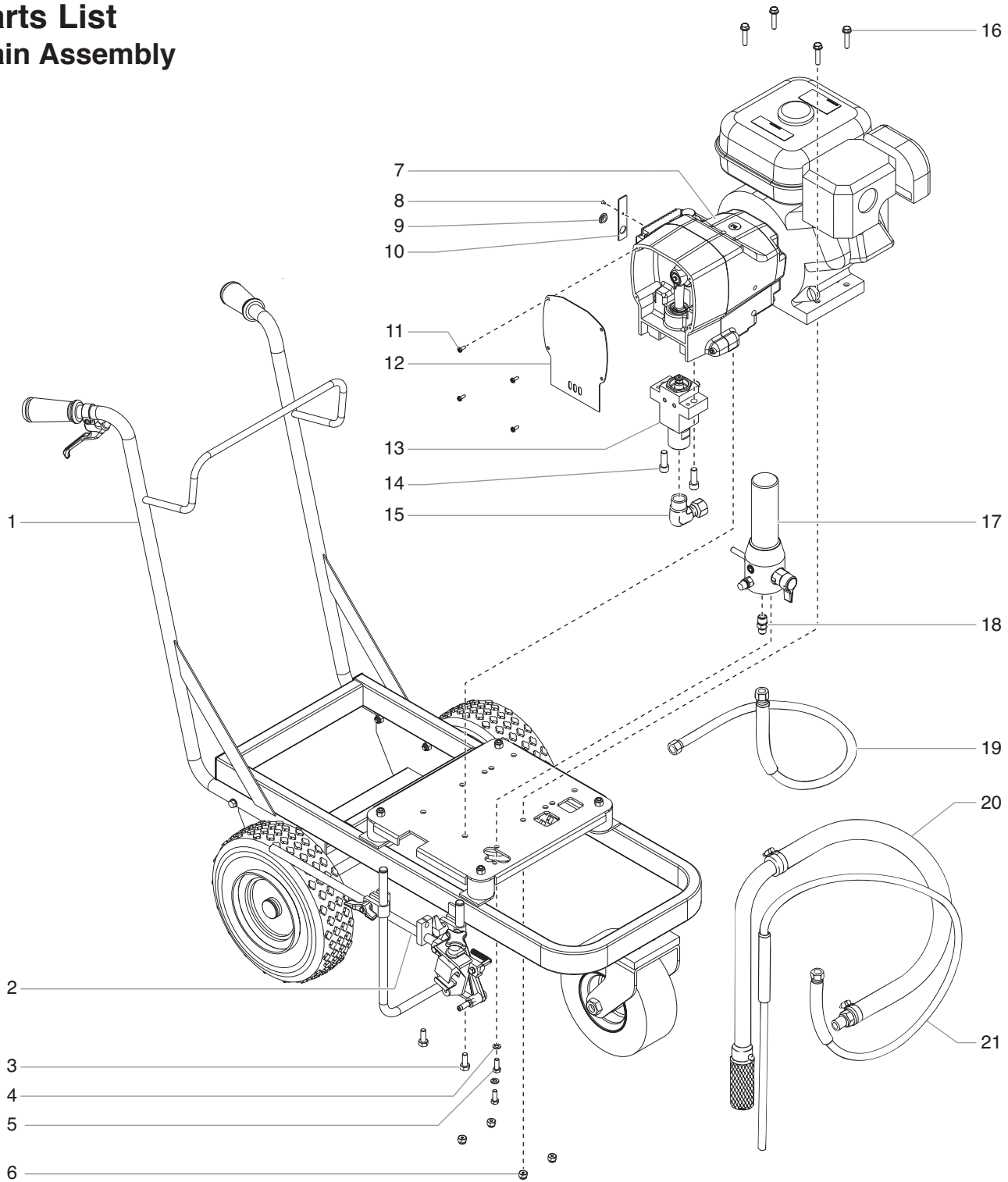

Item	Part #	Description	Quantity	Item	Part #	Description	Quantity
1	779-277	Cart assembly.....	1	14	700-678	Socket screw	2
2	779-276	Gun holder assembly.....	1	15	779-286	Swivel elbow	1
3	862-436	Hex screw	2	16	700-652	Hex screw	4
4	860-002	Lock washer.....	2	17	-----	Filter assembly (see separate listing).....	1
5	860-535	Hex screw	2	18	812-003	Nipple.....	1
6	763-549	Lock nut	4	19	755-233	Fluid hose	1
7	-----	Drive assembly (see separate listing)	1	20	779-295	Siphon hose assembly	1
8	704-282	Screw	1	21	779-266	Return hose assembly.....	1
9	704-281	Port plug	1	22	316-505	Material hose, 1/4" x 50' (not shown)	1
10	755-172	Control cover	1	23	581-092	Spray gun (not shown)	1
11	770-685	Screw	4	24	665-1708	Tip assembly (not shown).....	1
12	755-171	Cover	1	25	313-2297	Label (not shown)	1
13	755-173	Fluid section assembly	1				

Drive Assembly

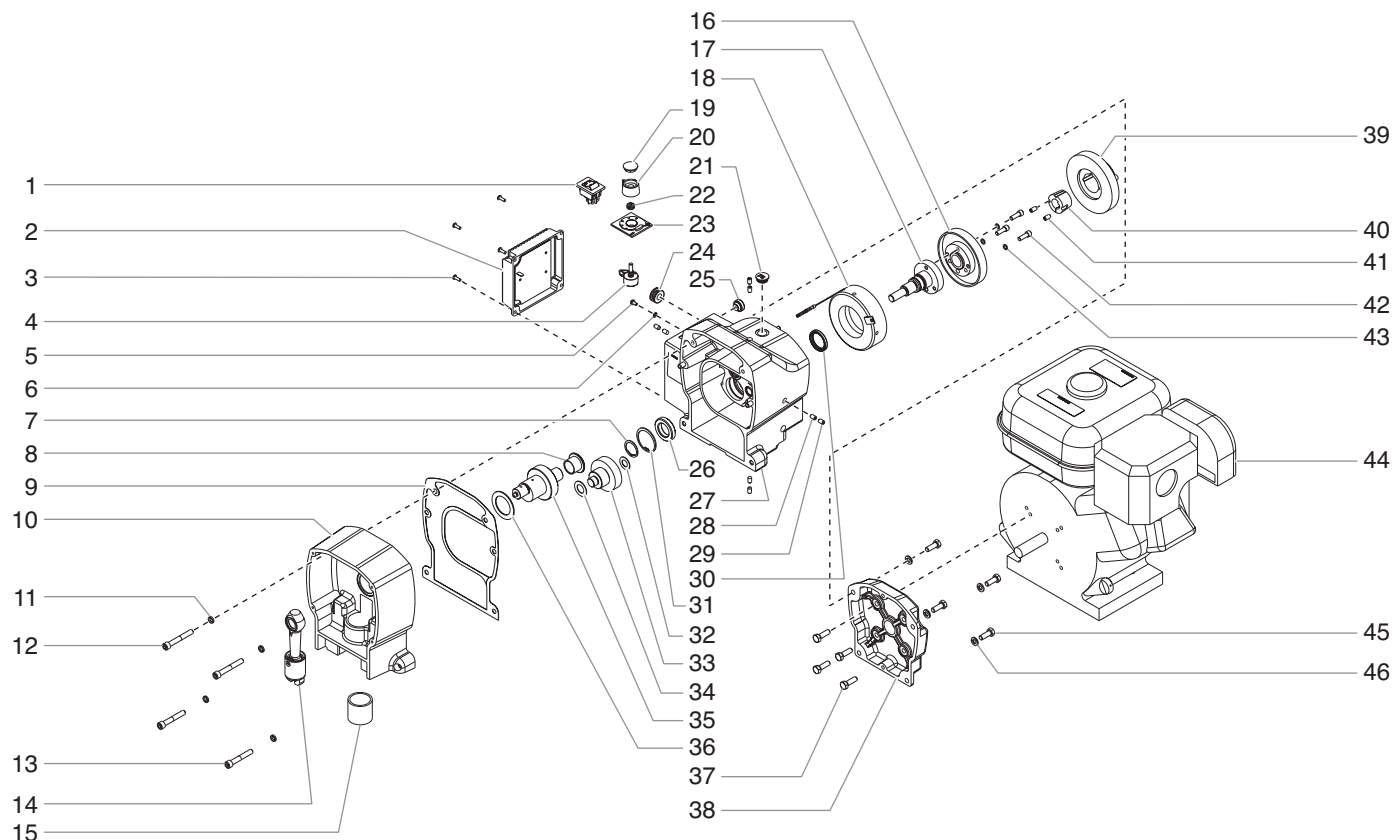

Item	Part #	Description	Quantity	Item	Part #	Description	Quantity
1	704-380	ON/OFF switch	1	26	750-015	Bearing	1
2	755-170	Electronic pressure control assembly.....	1	27	755-182	Gear housing (includes items 26, 30, and 31	1
3	700-139	Screw	4	28	763-525	Set screw, cone point	4
4	700-158	Potentiometer	1	29	755-224	Set screw, cup point	4
5	704-229	Ground screw	1	30	730-172	Grease seal	1
6	755-175	Lock washer	1	31	750-016	Retaining ring.....	1
7	730-144	Retaining ring.....	1	32	700-688	Thrust washer, 1/2".....	1
8	730-088	Thrust washer	1	33	730-167	Output gear assembly	1
9	755-176	Gasket	1	34	700-514	Thrust washer, 5/8".....	1
10	755-177	Pump housing assembly (includes item 15)	1	35	730-360	Crankshaft assembly	1
11	755-178	Lock washer.....	4	36	700-680	Thrust washer	1
12	755-179	Socket screw, 2.25"	2	37	755-183	Screw	4
13	755-180	Socket screw, 2"	2	38	755-184	Clutch housing	1
14	755-169	Slider assembly	1	39	755-209	Clutch armature assembly (includes items 40, and 41(2)).....	1
15	700-689	Bronze bearing	1	40	763-550	Taper lock bushing (includes item 41(2))....	1
16	755-203	Clutch rotor	1	41	763-566	Set screw	2
17	755-201	Drive shaft assembly	1	42	755-218	Socket screw	3
18	755-216	Clutch field assembly.....	1	43	755-215	Lock washer.....	3
19	700-175	Cap	1	44	750-200	Engine, 4.0 HP	1
20	700-159	Pressure control knob.....	1	45	860-535	Hex screw	4
21	764-018	Plug.....	1	46	860-002	Lock washer.....	4
22	700-176	Seal nut.....	1				
23	700-148	Mounting plate	1				
24	800-036	Grommet, 7/16".....	1				
25	755-181	Grommet, liquid tight	1				

NOTE: All electrical work should be performed by a Titan authorized service center.

Cart Assembly (P/N 779-277)

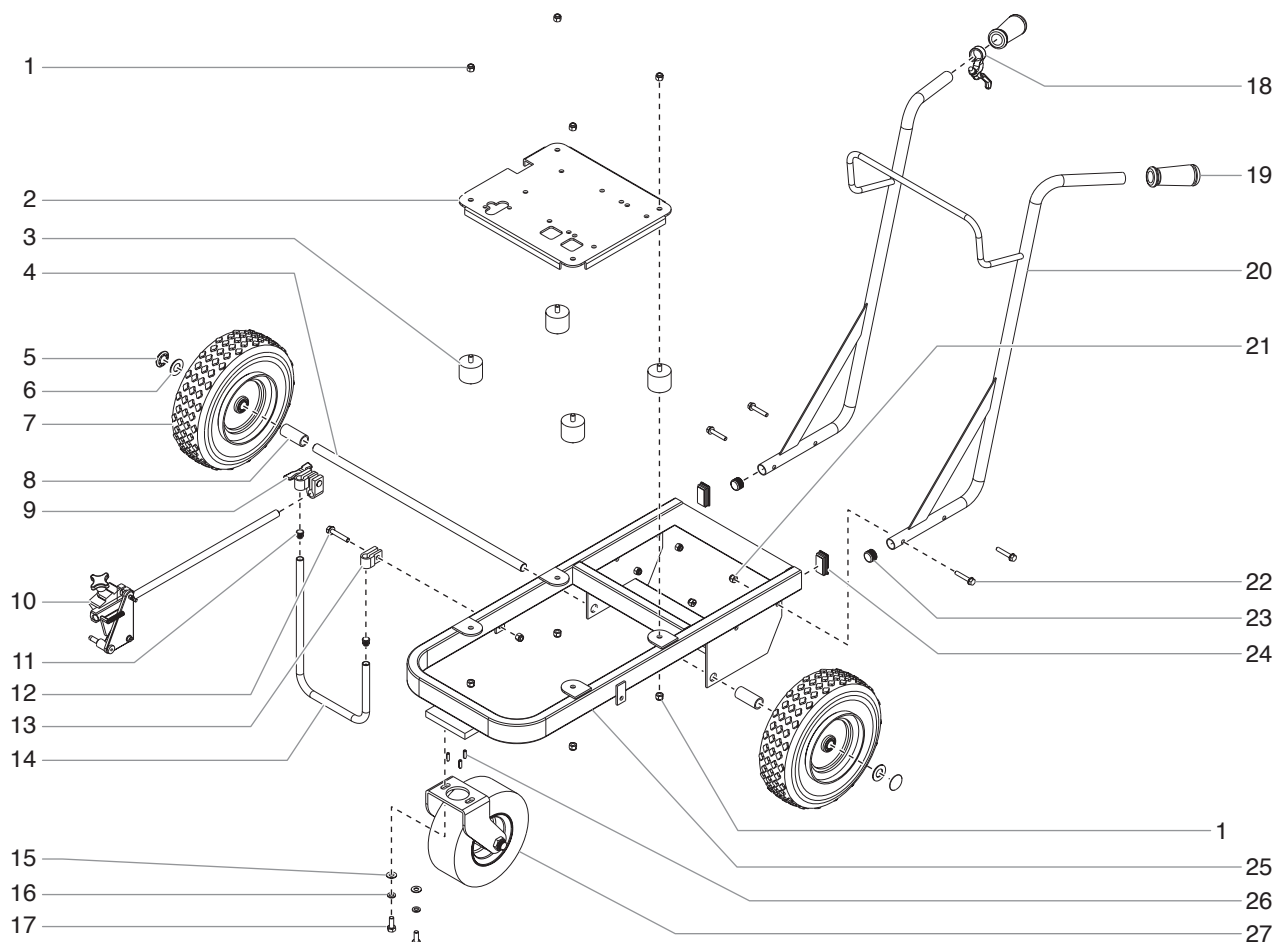

Item	Part #	Description	Quantity	Item	Part #	Description	Quantity
1	862-410	Lock nut	9	15	862-001	Flat washer	2
2	779-271	Pump mounting plate	1	16	862-002	Lock washer	2
3	757-042	Vibration mount	4	17	862-436	Hex screw	2
4	779-272	Axle	1	18	779-251	Trigger lever	1
5	800-019	Axle cap	2	19	424-245	Handle grip	2
6	870-004	Washer	2	20	779-270	Handle weldment	1
7	670-109	Wheel	2	21	763-549	Lock nut	4
8	449-120	Spacer	2	22	761-178	Hex screw	4
9	779-083	Gun holder clamp assembly	1	23	700-674	End cap	2
10	779-276	Gun holder assembly	1	24	779-121	Plug	2
11	779-282	Plug	2	25	779-269	Frame	1
12	862-460	Support bar clamp hex screw	1	26	779-283	Roll pin	3
13	779-051	Support bar clamp	1	27	779-275	Wheel assembly	1
14	779-273	Gun support bar	1	28	779-268	Gun cable (not shown)	1

Fluid Section Assembly (P/N 755-173)

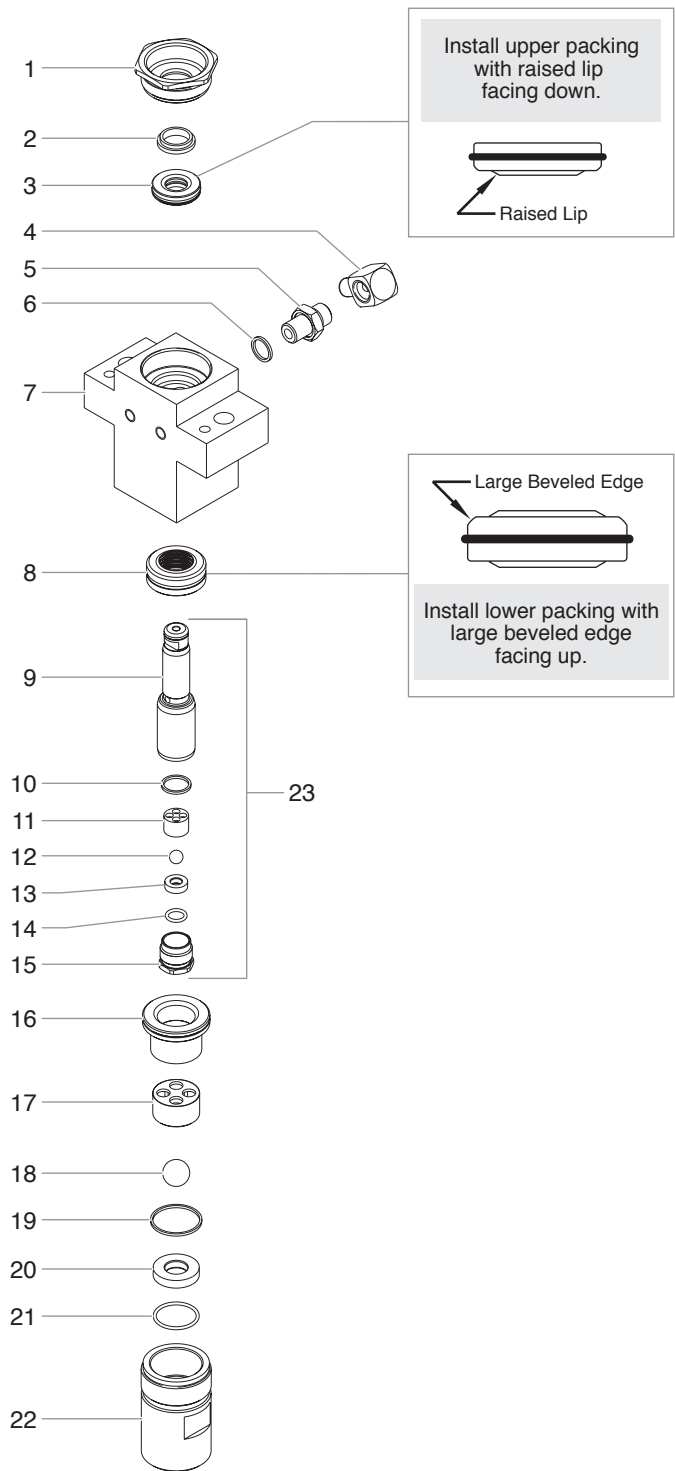

Item	Part #	Description	Quantity
1	730-508	Retainer nut	1
2	700-587	Piston guide	1
3	755-166	Upper packing assembly	1
4	755-185	Elbow, 90°	1
5	490-109	Fitting	1
6	700-804	Gasket	1
7	730-505	Fluid section housing	1
8	755-167	Lower packing assembly	1
9	704-089	Piston	1
10	762-111	Outlet valve seal	1
11	762-135	Outlet cage	1
12	762-144	Outlet valve ball	1
13	762-134	Outlet valve seat	1
14	762-057	O-ring	1
15	762-073	Outlet valve retainer	1
16	755-186	Piston bushing	1
17	730-510	Inlet cage	1
18	762-145	Inlet valve ball	1
19	700-821	Inlet valve seal	1
20	762-137	Inlet valve seat	1
21	762-058	O-ring, PTFE	1
22	755-187	Inlet valve housing	1
23	704-090	Piston assembly (includes items 9-15)	1
	755-165	Repacking kit (includes items 2, 3, 6, 8, 10, 12, 14, 18, 19, 21)	
	755-193	Lower packing insertion tool	

NOTE: When repacking the fluid section, make sure the raised lip on the bottom of the lower packing is fully outside the packing around the piston rod after insertion of the piston rod.

Electrical Schematic

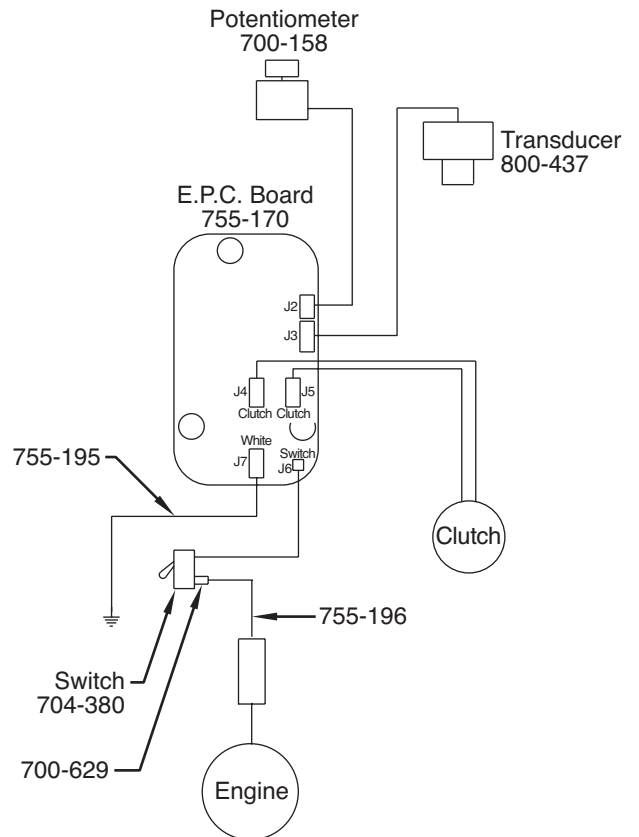

Filter Assembly

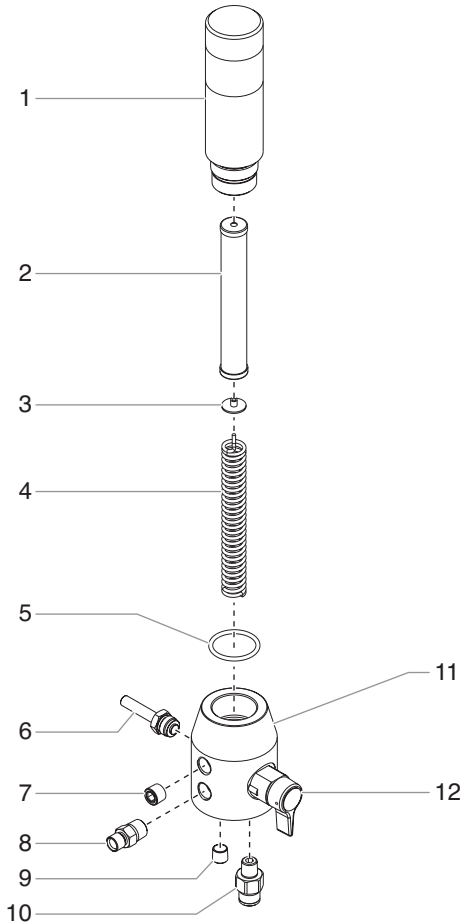

Item	Part #	Description	Quantity
1	755-190	Filter body	1
2	730-067	Filter, 60 mesh	1
3	702-251	Filter spring adapter	1
4	757-105	Core spring	1
5	755-191	O-ring, PTFE	1
6	800-437	Transducer	1
7	800-908	Plug	1
8	812-003	Outlet fitting	1
9	800-907	Plug	1
10	800-267	Fitting	1
11	755-192	Filter housing	1
12	800-915	PRIME/SPRAY valve assembly	1

PRIME/SPRAY Valve Assembly (P/N 800-915)

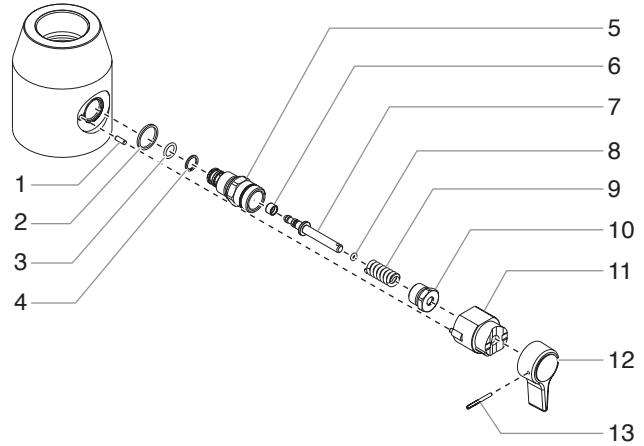

Item	Part #	Description	Quantity
1	700-823	Dowel pin	1
2	700-537	Gasket	1
3	222-012	O-ring, PTFE	1
4	221-012	O-ring, Viton	1
5	700-253	Valve housing	1
6	800-910	Valve seat	1
7	700-250	Valve stem	1
8	700-721	O-ring, Viton	1
9	800-926	Spring	1
10	700-248	Valve retainer	1
11	700-251	Cam base	1
12	700-697	Valve handle	1
13	700-759	Groove pin	1

Wheel Assembly (P/N 779-275)

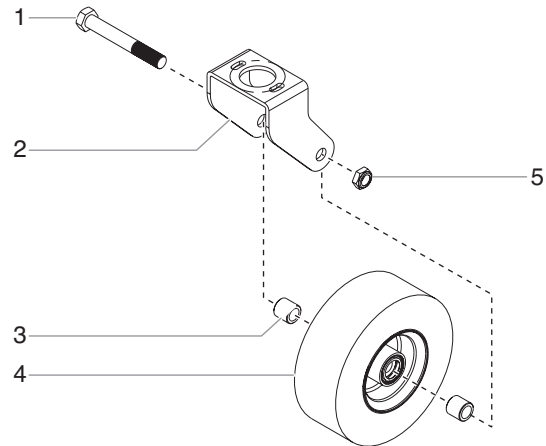

Item	Part #	Description	Quantity
1	779-018	Axle	1
2	779-011	Frame	1
3	779-017	Spacer	2
4	779-016	Wheel	1
5	779-019	Lock nut	1

Siphon Hose Assembly (P/N 779-295)

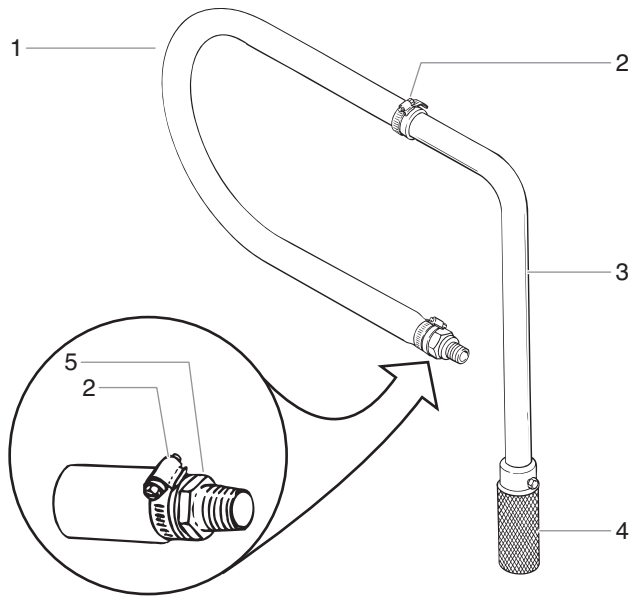

Item	Part #	Description	Quantity
1	779-287	Hose, 40".....	1
2	103-682	Hose clamp.....	2
3	103-550	Tube.....	1
4	103-625	Intake screen.....	1
5	194-661	Adapter.....	1

Return Hose Assembly (P/N 779-266)

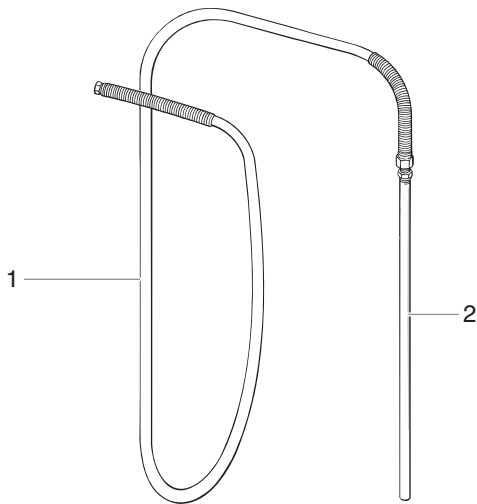

Item	Part #	Description	Quantity
1	779-265	Hose assembly.....	1
2	103-117	Tube.....	1

Gun Holder Assembly (P/N 779-276)

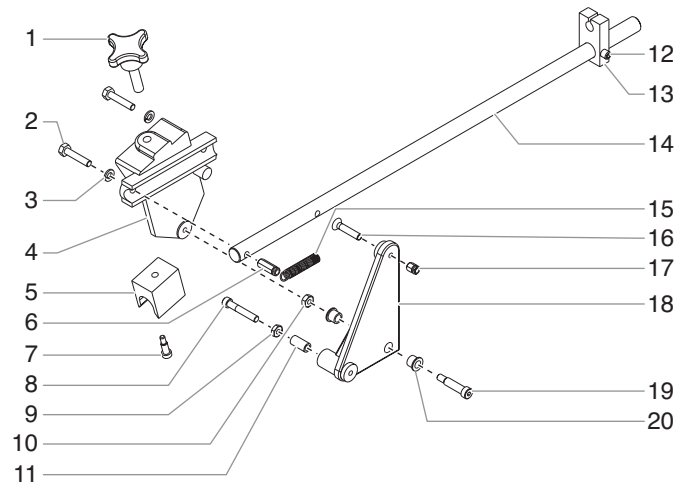

Item	Part #	Description	Quantity
1	756-034	Gun clamping knob.....	1
2	858-644	Hex screw.....	2
3	858-002	Lock washer.....	2
4	424-201	Gun holder.....	1
5	779-106	Clamp block.....	1
6	759-057	Spring holder, long.....	1
7	756-037	Shoulder screw.....	1
8	858-653	Screw.....	1
9	858-603	Jam nut.....	1
10	858-601	Hex nut.....	1
11	424-249	Sleeve bearing.....	1
12	860-520	Set screw.....	1
13	779-274	Cable block.....	1
14	424-224	Support arm.....	1
15	759-058	Return spring.....	1
16	703-079	Screw.....	1
17	759-056	Spring holder, short.....	1
18	424-202	Trigger lever.....	1
19	860-936	Screw.....	1
20	424-248	Flanged bearing.....	1

Labels

Part #	Description
313-2297	Logo label, front
755-197	Warning label, explosion
755-198	Warning label, injection
313-1847	Shock hazard label
755-232	"No Oil" label

Limited Warranty

Titan Tool Inc. warrants all equipment manufactured by it and bearing its brand names to be free from defects in material and workmanship at the time of sale by an authorized Speeflo distributor. Titan Tool Inc. will for a period of twenty-five months from the date of sale, repair or replace any part of the equipment proven defective. Repair or replacement under this warranty shall be purchaser's sole remedy for breach of this warranty. Products furnished by but not manufactured by Titan Tool Inc. (such as hose, motors, engines, etc.) will carry only the warranty of the manufacturer, if any. (TITAN TOOL INC. DOES NOT WARRANTY AND DISCLAIMS ALL IMPLIED WARRANTIES OF MERCHANTABILITY AND FITNESS FOR A PARTICULAR PURPOSE FOR ACCESSORIES, MATERIALS, EQUIPMENT, COMPONENTS AND PRODUCTS NOT MADE BY TITAN TOOL INC.).

This warranty shall not apply if the product has been subject to misuse, negligence, accident or tampering or has not been operated or installed in accordance with Titan Tool Inc.'s recommendations. This warranty does not cover and Titan Tool Inc. shall not be liable for any damage, wear or malfunction caused by improper or inadequate maintenance, abrasion, corrosion or substitution of components, parts or hydraulic fluid not supplied by Titan Tool Inc. Titan Tool Inc. shall not be liable for the improper design, manufacture, installation, operation or maintenance of accessories, components or materials not supplied by Titan Tool Inc. Titan Tool Inc. shall not be liable for damage or wear caused by incompatibility with Titan Tool Inc. equipment or materials, equipment or accessories not supplied by Titan Tool Inc.

This warranty applies only to the original purchaser and only when the equipment is installed, operated and maintained in accordance with Titan Tool Inc.'s written recommendations or instructions. Purchaser must, with transportation prepaid, return the equipment claimed to be defective to Titan Tool Inc. or to an authorized Warranty Service Center for verification of the claimed defect. If the alleged defect is verified, Titan Tool Inc. will, at Titan Tool Inc.'s option, repair or replace any defective parts. The equipment will be returned including prepayment of transportation charges to the original purchaser. If no defects in material and workmanship are found, repairs will be made by Titan Tool Inc. at a reasonable charge. Charges may include the cost of parts, labor and freight.

No statement or recommendation made or assistance given by Titan Tool Inc. or its representatives to purchaser, lessee or user or its representatives shall constitute a warranty by Titan Tool Inc. or a waiver or modification of any of the provisions hereof to create any liability for Titan Tool Inc. No sample or model shall create an express warranty that the products shall conform to any sample or model exhibited by Titan Tool Inc.

TITAN TOOL INC. DISCLAIMS TO THE FULL EXTENT PERMITTED BY LAW ALL WARRANTIES, EXPRESSED OR IMPLIED, INCLUDING ANY WARRANTY OF MERCHANTABILITY OR WARRANTY OF FITNESS FOR A PARTICULAR PURPOSE AND ANY NON CONTRACTUAL LIABILITIES INCLUDING PRODUCT LIABILITY BASED ON NEGLIGENCE OR STRICT LIABILITIES. Every form of liability is expressly excluded and denied for direct, indirect, special or consequential damages or loss. This warranty shall be in lieu of any other warranty expressed or implied. The terms of this warranty constitute purchaser's sole and exclusive remedy. In no case shall Titan Tool Inc.'s liability exceed the amount of the purchase price. Any action for breach of warranty must be brought within two (2) years of the date of sale.

Material Safety Data Sheets (MSDS) are available on Titan's website or by calling Technical Service.



United States Sales & Service

1-800-526-5362

Fax 1-800-528-4826

107 Bauer Drive
Oakland, NJ 07436

www.titantool.com

Canadian Branch

1-800-565-8665

Fax 1-905-856-8496

200 Trowers Road, Unit 7B
Woodbridge, Ontario L4L 5Z8

International

1-201-337-1240

Fax 1-201-405-7449

107 Bauer Drive
Oakland, NJ 07436 USA